



Commercial
BATTERY



E-MATE 125-261-L

User Manual

Catalogue

E-MATE 125-261-L.....	1
Preface	1
Main Contents.....	1
Target Reader.....	1
Manual Warning Sign Definition.....	1
1 Safety Precautions	2
1.1 Safety Instructions 	2
1.2 Personnel Requirements 	2
1.3 Electrostatic Protection 	3
2 Product Introduction	3
2.1 Naming Rule	3
2.2 Energy Storage Systems Overview	3
2.2.1 Systems Overview	3
2.2.2 Working Principle.....	4
2.3 Energy Storage Cabinet Exterior View	4
2.4 Technical Parameters.....	5
2.5 Main Components	7
2.5.1 Cabinet.....	7
2.5.2 Battery Pack.....	9
2.5.3 High-Voltage Box.....	10
2.5.5 Power Distribution Box.....	11
2.5.6 Liquid Cooling Unit.....	12
2.5.7 PCS.....	12
2.5.8 EMS/HMI.....	12
2.5.9 Fire Safety System.....	14
3 Product Lifting, Transport, Storage	17
3.1 Hoisting Operation	17
3.1.1 Safety Precautions for Hoisting Operations.....	17
3.1.2 Preparations Before Hoisting	17
3.1.3 Hoisting Process	17
3.2 Forklift Operation	18
4 Equipment Installation.....	20
4.1 Installation Precautions.....	20
4.1.1 Installation Requirements.....	20
4.2 Pre-installation.....	20
4.2.1 Installation Environmental Requirements.....	20
4.2.2 Foundation requirements.....	21
4.2.3 Equipment Ventilation Requirements.....	22
4.2.4 Installation Tool Preparation	22
4.2.5 Pre-installation Inspection	24
4.3 Energy Storage System Structure Installation	24
4.3.1 Cabinet Package Removing & Installation	24
4.3.1 Pack Installation in Cabinet.....	28
4.3.2 Structure Safety Check.....	28
4.4 Energy Storage System Electrical Connection	28
4.4.1 Energy Storage System Interface Description.....	29
4.4.2 Wiring Description Sheet	30
4.5 Electrical Wiring.....	31

- 4.5.1 External AC Cable Connection and Procedure 31
- 4.5.2 Checking the Equipment After Wiring 31
- 5 Product Operation 32**
- 5.1 Energy Storage System Power-up Process 32
- 5.1.1 Pre-power-up Check 32
- 5.1.2 Power-up Procedure 32
- 5.1.3 Power Shutdown Procedure 34
- 5.2 EMS Interface Operation 35
- 5.2.1 EMS Interface Introduction 35
- 5.2.2 EMS Basic Setting 38
- 5.2.3 EMS Controlled Charge/Discharge Steps 42
- 5.2.4 EMS Controlled Power off Steps 45
- 5.3 Emergency Shutdown Procedure 46
- 6 Battery System Maintenance Instructions 47**
- 6.1 System Usage Requirements 47
- 6.1.1 Precautions Before Maintenance 47
- 6.1.2 Maintenance (Every two years) 47
- 6.1.3 Long Without System Usage Requirements 47
- 6.1.4 Maintenance (Once a year) 48
- 6.2 Battery Maintenance 49
- 6.2.1 Maintenance Overview 49
- 6.2.2 Battery Storage 49
- 6.3 Alarm Reference & Troubleshooting 49
- 6.3.1 Liquid Cooler Alarm Troubleshooting 49
- 6.3.2 EMS Alarm Troubleshooting 54
- 6.3.3 BMS Alarm Troubleshooting 55
- 6.3.4 PCS Alarm Troubleshooting 59

Preface

Main Contents

This manual describes the E-MATE 125-261-L introduction, transport, installation, operation, maintenance and troubleshooting. Before using this product, be sure to read the manual carefully and operate the energy storage system according to the methods described in this manual, or equipment or personal injury may result.



Target Reader

This document is primarily intended for users:

1. Technical support engineers: responsible for providing professional technical support and consulting to solve technical problems.
2. System Installation Engineer: responsible for on-site installation, wiring and hardware configuration of the energy storage system.
3. Testing engineers: responsible for system debugging and testing to ensure that the system operates normally in accordance with the design requirements.
4. Maintenance engineers: responsible for daily system maintenance and troubleshooting, to maintain long-term stable operation of the system.
5. Product end-users: end-users who utilize energy storage systems and need to understand basic operation and maintenance.

Manual Warning Sign Definition

To help users identify potential safety risks and take appropriate precautions to ensure safety when using the energy storage system. Users should read the manual carefully before using the energy storage system and strictly observe all safety warnings and operating instructions in the manual.

Notation	Descriptions
	Used to warn of an imminently hazardous situation which, if not avoided, will result in death or serious bodily injury.
	Used to convey an equipment or environmental safety warning message indicating a hazard with a medium level of risk that may result in death or severe typhoid fever if not avoided.
	Hazards with a low level of risk of causing minor or moderate harm if not avoided.

1 Safety Precautions

1.1 Safety Instructions

Please strictly observe the terms of the safety regulations in this product manual. In order to avoid possible injury or death and property damage during the use of this product, as well as to improve the service life and use efficiency of this product, please be sure to read the safety regulations carefully.

1. Do not immerse the battery in water;
2. Improper use and storage of the battery poses a risk of fire, explosion, and burns; do not disassemble, crush, incinerate, heat, or throw batteries into fire;
3. Do not expose the battery to fire or prolonged exposure to temperatures exceeding the temperature conditions specified in this manual, as this may result in fire;
4. When batteries reach the end of their useful life, used batteries should be disposed of in a timely manner in accordance with local recycling or waste regulations;
5. Do not disassemble, dismantle or recondition the battery in any way without authorization;
6. Do not mix different sizes and brands of lithium-ion batteries;
7. Do not use the battery if it emits a strange odor, heat, deformation, discoloration or any other abnormal phenomenon;
8. Do not short-circuit the positive and negative terminals of the battery, otherwise strong current and high temperature may cause personal injury or fire;
9. Connect the positive and negative terminals of the battery in strict accordance with the labeling and instructions, and prohibit reverse or series wire charging;
10. Prohibit over charging/over discharging of the battery, otherwise it may cause overheating and fire accidents;
11. Avoid skin and eye contact with the electrolyte when it is leaking. In case of contact, wash the contact area immediately with plenty of water and seek medical help;
12. It is prohibited for any person or animal to ingest any part of the battery or any substance contained in the battery;
13. Batteries are potentially hazardous and must be operated and maintained with appropriate protective measures. Failure to do so may result in serious personal injury and property damage;
14. Prohibit any behavior that may cause deformation of the battery, such as needling, hammering, etc., which may cause a short circuit or fire in the battery.
15. Customer setup for off-grid operation requires grid isolation to avoid grid incoming calls damaging the PCS.

1.2 Personnel Requirements

1. When operating or maintaining the energy storage cabinet, it's necessary to wear a helmet, insulated gloves, insulated shoes, goggles, it is strictly prohibited to wear watches and other metal jewelry;
2. Only qualified electricians and trained personnel can operate and maintain this product, and complete professional electrical equipment is required;
3. Personnel responsible for the installation and maintenance of the equipment must be strictly trained in the correct operation methods, and be aware of the various safety precautions and the relevant standards of the country/region where they work;

4. Replacement of equipment or parts (including software) must be done by authorized professionals;
5. Keep persons other than those operating the equipment away from the equipment.

1.3 Electrostatic Protection

Accumulation of static electricity may cause electric shocks, fires, explosions, failure and damage of electronic devices, etc. There are circuit boards or other static-sensitive components in the energy storage cabinet. Board or other static-sensitive components, in order to prevent or reduce the harm of static electricity, it is necessary to do a good job of static protection, and thus inhibit the generation of static electricity, accelerate the leakage of static electricity, static electricity neutralization. The prevention methods include but are not limited to:

1. During the component replacement process, keep all the components that have not been installed in the ESD shielding bag, and the temporarily removed device is placed on a foam mat with anti-static function;
2. Do not touch solder joints, pins or exposed circuitry.

2 Product Introduction

2.1 Naming Rule

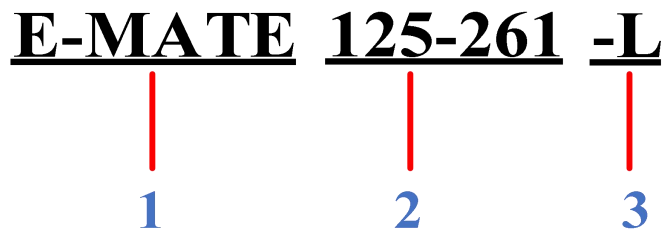

NO.	Meaning	Explanation of Parameter Values
1	Series Name	E-MATE
2	Energy Level	125-261: Rated Power 125kW Rated Energy 261kWh
3	Cooling Method	L: Liquid Cooling

2.2 Energy Storage Systems Overview

2.2.1 Systems Overview

This energy storage system adopts the form of one-piece outdoor cabinet, which integrates battery Pack, High Voltage (HV) box, Energy Management System (EMS), Power Conversion System (PCS), Battery Cluster, Heating Ventilating and Liquid Cooling Unit, Fire Extinguishing device, Water sensor, Temperature and Humidity sensor, Smoke Sensor and Electric Distribution Unit.

2.2.2 Working Principle

The system consists of 1 PCS 125 kW bidirectional energy storage inverter, 5 PCS battery packs in series and 1 PCS HV box. The main circuit of the HV box is mainly composed of isolation switch, fuse, charging contactor, discharge contactor, negative contactor, pre-charged contactor, pre-charged resistor and hall current sensor. The principle diagram of the system is as follows:

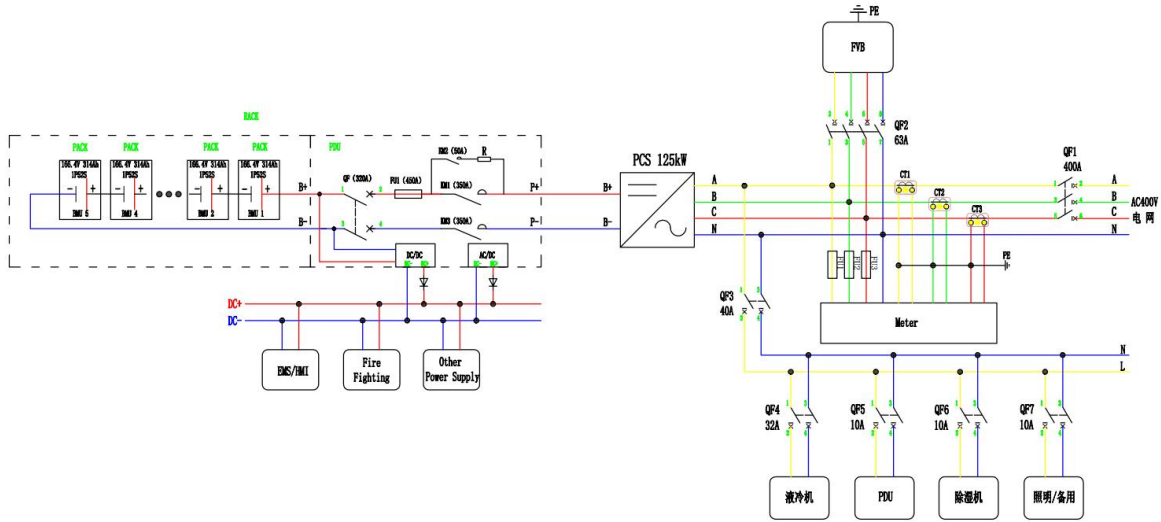

Fig. 2-1 E-MATE 125-261-L System Primary Schematic Diagram

2.3 Energy Storage Cabinet Exterior View

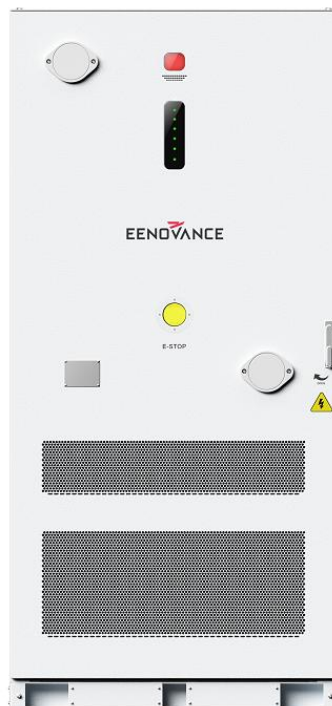

Fig. 2-2 E-MATE 125-261-L Liquid Cooling Energy Storage Cabinet Exterior View

2.4 Technical Parameters

No.	Items	Spec.	Remarks
System Parameters			
1	Rated Power	125 kW	
2	Rated Energy	261kWh	
3	Rated DC Voltage	832VDC	
4	Rated AC Voltage	400VAC	
5	System Voltage	1000VDC	
6	Charge/Discharge Current	157 A/157 A	
7	Operating Temperature Range	-30°C~+55°C	Derating below-15 °C or above 45 °C
8	IP Level	IP55	
9	Corrosion Resistance	C4	
10	Dimension	1100*1424*2350 mm	
11	Weight	2700 kg	
Pack Parameters			
12	Configuration	1P52S	
13	Rated Capacity	314 Ah	
14	Rated Voltage	166.4V	
15	Voltage Range	130V-189.8V	
16	Rated Energy	52.249kWh	
17	Charge /Discharge Current	≤0.5 P	
18	Altitude	2000 m	
19	IP Level	IP67	
20	Dimension	790 *1140 *247mm	W*D*H
21	Weight	335 ± 2kg	
AC Parameters			
22	Rated Output Power	125kW	
23	Rated Grid Voltage	400 V ± 15%	
24	Rated Current	144 A	

25	Rated Frequency	50 Hz/60 Hz ± 2.5 Hz
26	Output THDI	<3%
27	Power Factor	-1~1
28	AC Output Type	3W+PE
29	Charge/Discharge Time	Conversion <100 ms
30	Maximum Efficiency	98.5%

HV Box Parameters

31	Rated Voltage	1500 V	
32	Rated Current	250 A	
33	IP Level	IP54	
34	Dimension	480 * 600 * 160 mm	W*D*H
35	Weight	30.5kg	

Other Parameters

36	Fire Fighting System	Aerosol
37	Altitude	2000 m
38	Noise	<75dB
39	Environment Humidity	0~95°C, non-condensing
40	Cooling Method	Liquid Cooling
41	Environmental Requirement	ROHS
42	Communication Protocol	CAN/RS485
43	Design Service Life	8000 cycles (25 ± 2 °C , 0.5P/0.5P, 70% EOL, 90% DOD /10 years, whichever comes first)
44	Compliance	UN38.3, UN3536, EN 62477-1, EN IEC 61000-6-2, EN IEC 61000-6-4

2.5 Main Components

2.5.1 Cabinet

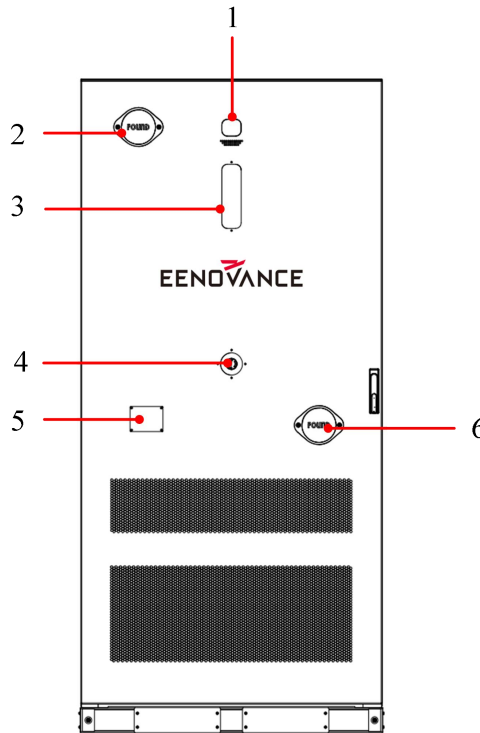

Fig. 2-3 Description of Cabinet Components (Closed State)

Table 2-1 Cabinet Front Door Components

No.	Components	Amounts	Remark
1	Audible and visual alarm	1	For internal equipment temperature, smoke and other abnormal alarm
2	Exhaust valve (air venting)	1	Combustible gas leakage from the interior can be directed to the outside
3	Indicator light display	1	Display power and status indication
4	Emergency stop button	1	Press this button when the device is in emergency.
5	Product nameplate	1	Product information
6	Exhaust valve (air inlet)	1	Combustible gas leakage from the interior can be directed to enter the air

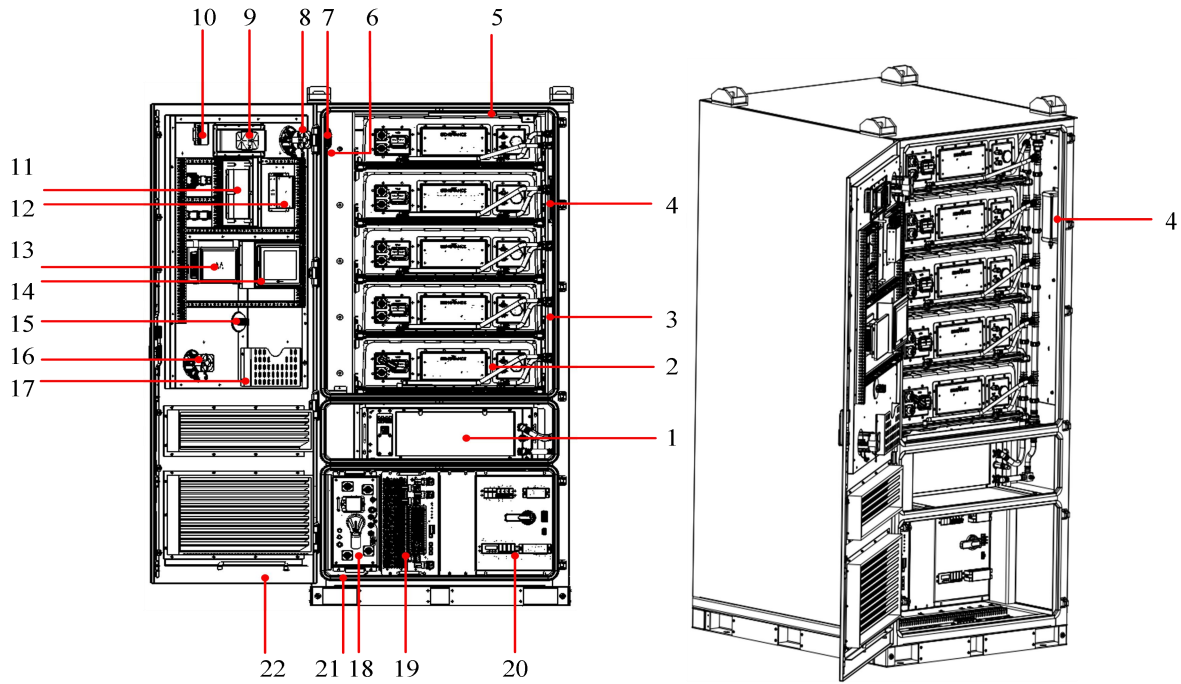

Fig. 2-4 Introduction to Cabinet Components (Open Door State)

Table 2-2 Cabinet Component Configuration

No.	Components	Amounts	Remark
1	Liquid cooling unit	1	Deliver coolant to cool the battery pack
2	Battery pack	5	The battery box is composed of 52 battery cells in series
3	Liquid cooling cable	1	Deliver coolant to cool the battery pack
4	Aerosol fire extinguishers	2	1.69M ³
5	Access sensor	1	Monitoring of door opening and closing status
6	Heat detector	1	For temperature detection
7	Smoke detector	1	For smoke detection
8	exhaust valve	1	
9	Audible and visual alarm	1	
10	Combustible gas detector	1	Checking the concentration of combustible gases
11	Indicator Light Panel	1	
12	Serial Port Server	1	
13	EMS HMI	1	Monitor data and scheduling locally
14	BAU DMI	1	

15	Emergency stop button	1	Press this button when the device is in emergency
16	Exhaust valve (air inlet)	1	Suck external air into the battery cabinet.
17	File box	1	File documents
18	HV BOX	1	The management unit of the battery cluster high voltage power circuit
19	PCS	1	125 kW energy storage converter
20	Power Distribution Box	1	
21	Water immersion sensor	1	
22	Cabinet	1	/

2.5.2 Battery Pack

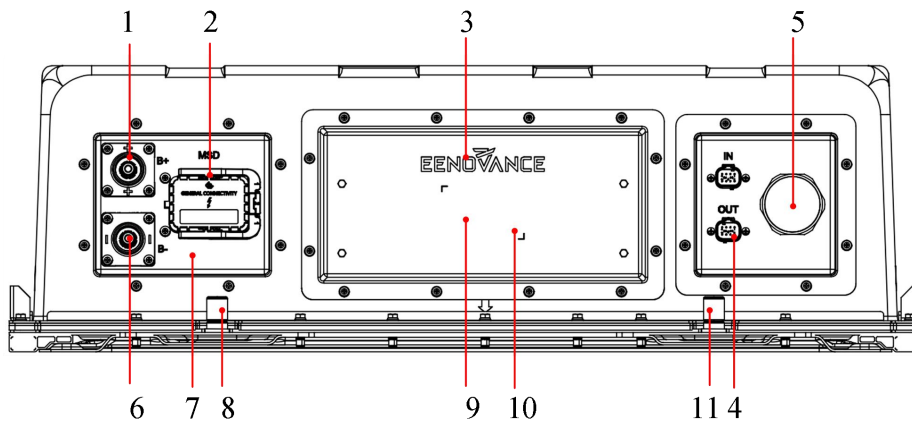

Fig. 2-5 Pack Panel Schematic Diagram

Table 2-3 Pack Device Description

No.	Description	Remark
1	Positive Connector	ESS-250A-70-B/S-OR-01
2	MSD	Service Switch
3	LOGO	/
4	Communication Connector	SFR10A/SFR10C
5	Pressure Relief Valve	/

6	Negative Connector	ESS-250A-70-B/S-BK-01
7	Warning Label	/
8	Liquid Outlet	Coolant Output Port
9	Nameplate	/
10	Bar Code	
11	Liquid Inlet	Coolant Input Port

2.5.3 High-Voltage Box

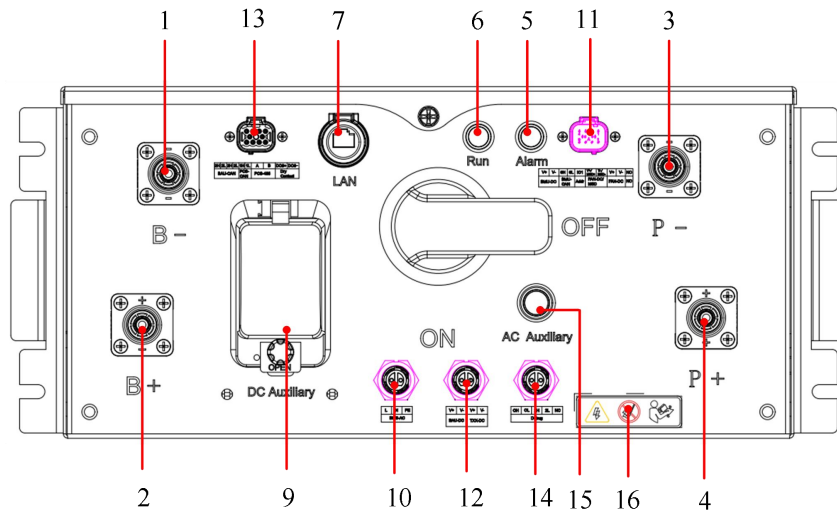

Fig. 2-6 HV Box Panel Schematic Diagram

Table 2-4 HV Box Device description

NO.	Description	Remark
1	B-	Battery cluster total negative
2	B+	Battery Cluster Total Positive
3	P-	PCS Negative interface
4	P+	PCS Positive Connector
5	Alarm	Malfunction warning light, when the system is in fault, it is always on, otherwise it is off
6	Run	Running light, the system is normally on high voltage and no fault is always on, otherwise it is off
7	LAN	External network communication port
8	AC Auxiliary	High-voltage box power-on switch
9	DC Auxiliary	/

10	COM1	/
11	COM2	/
12	COM3	/
13	COM4	/
14	COM5	/
15	Bar Code	High-Voltage Box Information
16	Warning Label	/
17	Logo	Supplier Name

2.5.5 Power Distribution Box

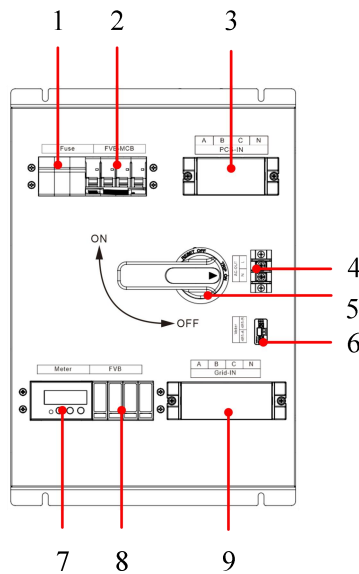

Fig. 2-8 Electrical Distribution Box Panel Schematic Diagram

Table 2-6 Electrical Distribution Box Device Description

NO.	Symbol/Name	Remark
1	Fuse	/
2	FVB MCB	/
3	PCS Input	Power cable input
4	AC Output	/
5	Circuit Breaker	/
6	Liquid unit COM	Liquid unit power supply
7	Meter	/
8	FVB	/
9	Grid Input	Grid cable input

2.5.6 Liquid Cooling Unit



Fig. 2-9 Liquid Cooling Unit Diagrammatic Sketch

Table 2-7 Liquid Cooling Unit Technical Parameters

No	Item	Spec.
1	Operation Temperature	-30~55 °C
2	Rated AC input Power Supply	220VAC~50HZ/60HZ
3	Rated Cooling Capacity	5000 W
4	Rated Power (Cooling/Heating)	5000/2000W
5	Rated Current (Cooling/Heating)	9.2/8.7A
6	Heating Power	2000W
7	Air Quantity	2300m ³ /h
8	Weight	≤120kg
9	IP Level	IP55
10	Refrigerating Fluid	R410a

2.5.7 PCS

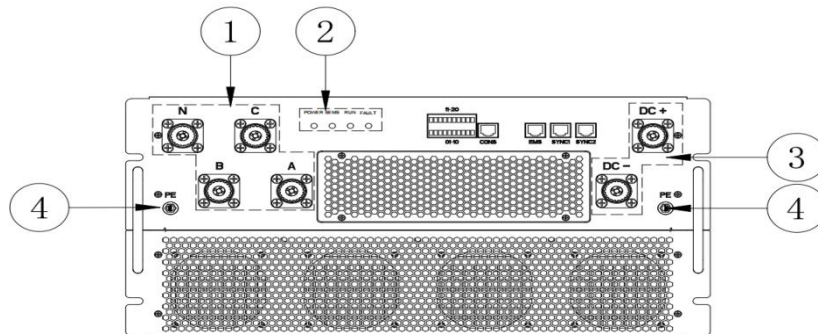

Fig. 2-10 PCS Panel Diagrammatic Sketch

Table 2-8 PCS Technical Parameters

NO.	Symbol/Name	Functional Description
1	AC Power terminal	Grid to PCS
2	Indicator light	Display the working status of the PCS
3	DC Power terminal	HV box to PCS
4	PE Terminal	Grounding Terminal (M6)

Table 2-8 Indicator function description

Indicator	Status	Functional Description
-----------	--------	------------------------

Power (Green)	Always on	Both battery and power grid connected
	Rapid flashing	Battery not connected
	Slow flashing	Grid not connected
	Always off	Both battery and power grid not connected
SEMS (Green)	Rapid flashing	Communication normal
	Always off	Communication abnormal
RUN(Green)	Always off	PCS stop
	Always on	PCS standby
	Rapid flashing	PCS running
FAULT(Red)	Slow flashing	Alarming
	Always on	Error and stop

2.5.8 EMS/HMI

EMS is responsible for the equipment status monitoring and energy optimization scheduling of BMS battery system, PCS converter system, temperature control system and fire protection subsystem

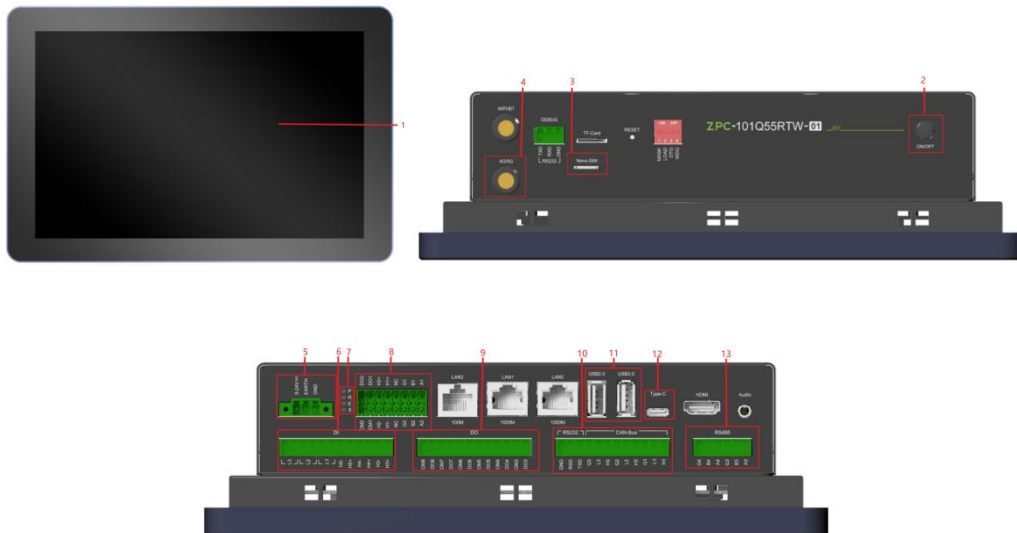

Fig. 2-11 EMS/HMI Schematic Diagram

Table 2-9 EMS / HMI Device Description

NO.	Symbol/Name	In use	Remark
1	Display Screen	✓	10.1 inches, 1280 × 800
2	ON/OFF	✓	Power Switch Button
3	Nano-SIM	✓	SIM card slot
4	4G/5G	✓	4G sucker antenna interface
5	Power Supply	✓	24V power supply
6	DI	✓	L1 is the water immersion device feedback,

			L2 is the emergency stop device feedback, L3 is the aerosol device feedback. H3 + is a temperature-sensitive terminal
7	Pilot Lamp	✓	P is the power indicator. R is the running state light of the system. E is the system error state lamp. S is the status indicator
8	DI&RS485	✓	H2 is a smoke-inductive terminal. H1 is the access switch terminal. A1 / B1 is a BMS communication terminal. A2 / B2 is PCS communication terminal
9	DO	✓	Exhaust valve push-out / retraction
10	CAN-BUS	✓	L1 / H1 is the communication line of combustible gas detector
11	USB	✓	Program update
12	Type C	✓	Mirror burning
13	RS485	✓	A3/B3 are the communication interfaces between the liquid cooling unit, dehumidifier, and light panel. A4/B4 are the communication interfaces for the electricity meter

2.5.9 Fire Safety System

The energy storage cabinet fire protection system includes pack-level and cluster-level fire protection. Pack-level fire protection can provide early detection of fire sources at the root of the pack and rapid-fire extinguishing, while cluster-level fire protection can focus on the external fire sources of the system, preventing their spread and inhibiting their growth.

2.5.9.1 Cluster-level Fire Protection

Cluster-level fire protection system can be divided into fire extinguishing system and explosion-proof exhaust system. When the battery is out of thermal control and combustible gas leaks, the explosion-proof exhaust system responds in time for air intake and exhaust. When a fire occurs, the fire extinguishing system acts quickly to detect, alarm and extinguish the fire.

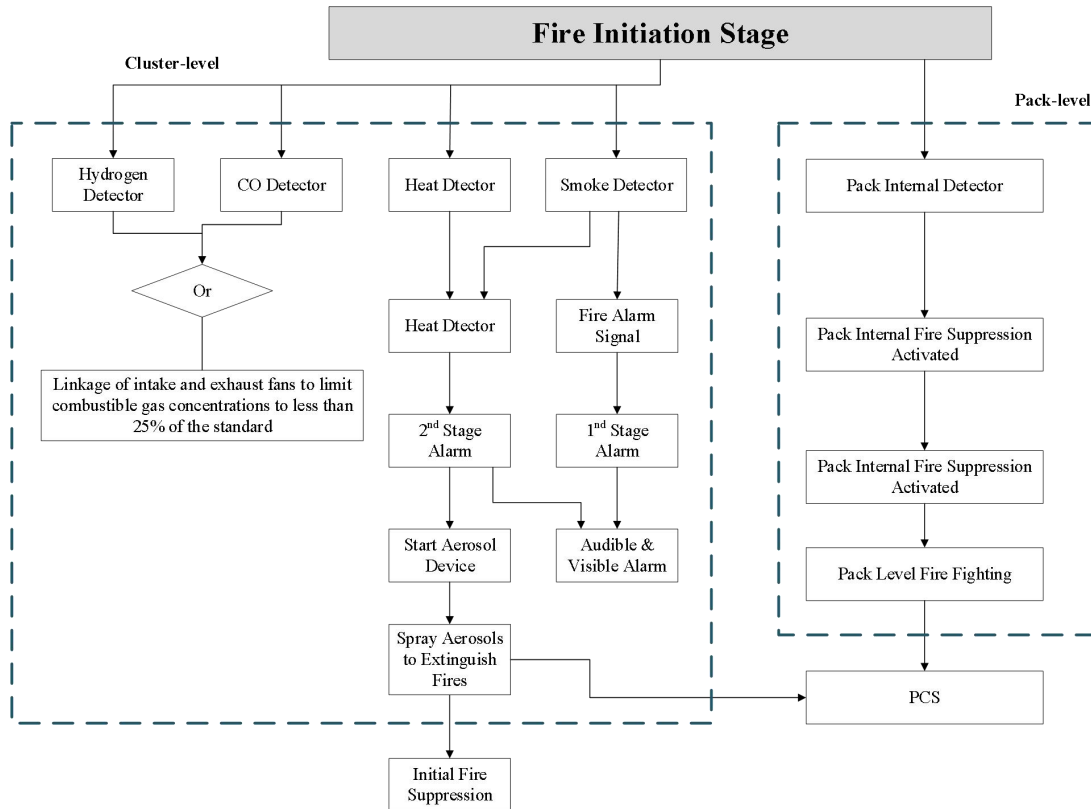

Fig. 2-12 Fire Control Logic Diagram

2.5.9.2 Fire Safety System Components

Table 2-10 Fire Safety System Components

Item	Name	Quantity
1	Temperature detector	1
2	Smoke detector	1
3	Audible and visual alarm	1
4	Aerosol extinguisher	1
5	Fire alarm	1
6	Inlet valve	1
7	exhaust valve	1

Firefighting Logic: When the smoke detector inside the cabinet detects a fire, the sound and light alarm outside the protected area will activate immediately to alert personnel to respond. when both the smoke and temperature detectors detect a fire simultaneously, they output an electrical signal, triggering the fire extinguishing device to initiate firefighting, and simultaneously sending a feedback signal to the EMS to notify personnel to handle the situation in a timely manner.

Valve Motion Logic: The explosion-proof ventilation system consists of a flammable gas detector, intake valves and fans, and exhaust valves and fans. When the flammable gas detector reaches the alarm threshold, it outputs an alarm signal, linking the intake/exhaust valves and fans to ventilate and exchange air, preventing the accumulation of flammable gases and the occurrence of deflagration phenomena.

2.5.9.2.1 Temperature detector

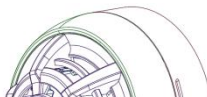
Temperature detector	Technology contents	Parameters
	Working Voltage	9VDC~28VDC
	Static Current	≤60 μA
	Alarm Current	10mA ≤ I ≤ 50 mA

Output Value	DC30V, 1A, Dry contact
Working Temperature	-10°C~+55°C
Ambient Humidity	≤95%, no condensing
Polarity	Yes

2.5.9.2.2 Smoke detector

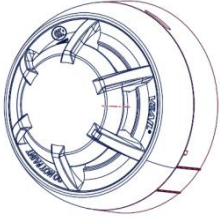
Smoke detector	Technology contents	Parameters
	Working Voltage	9VDC~28 VDC
	Static Current	≤60 μA
	Alarm Current	10mA≤I≤50 mA
	Output Value	DC30V, 1 A, Dry contact
	Working Temperature	-10°C~+55°C
	Ambient Humidity	≤95%, no condensing
	Polarity	Yes
	Sensor	Infrared photoelectric sensor

2.5.9.2.3 Audible and visual alarm

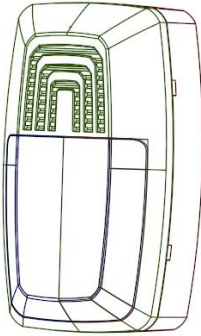
Audible and visual alarm	Technology contents	Parameters
	Working Voltage	24VDC (21V~28V)
	Static Current	≤50 mA
	Alarm Current	10mA≤I≤50 mA
	Blinking Frequency	1.4×(1±20%) HZ
	Working Temperature	-10°C~+55°C
	Ambient Humidity	≤95%, no condensing
	Sound Pressure Level	88dB~96 dB
	Implementation Criteria	EN54-3

2.5.9.2.4 Aerosol extinguisher

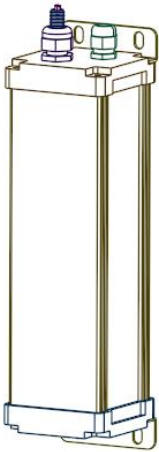
Aerosol extinguisher	Technology contents	Parameters
	Oxidizing Agent	Strontium nitrate 50-58%
	Spraying Time	≤15 s
	Spray Delay Time	≤2 s
	Weight	1145g±30 g
	Working Temperature	-30°C~+70°C
	Feedback Signal	Dry contact
	Start temperature	≥170°C
	Start current	≥170 mA
	Protecting Space	3 m ³

2.5.9.2.5 Fire alarms

Fire alarms	Technology contents	Parameters
	Working Voltage	24VDC (9~36V)
	Static Current	≤40 mA
	Working Temperature	-40°C~+70°C (long term operation) -10°C~+60°C (short time operation)

Start delay time	≤ 15s
Alarm Function	Temperature Alarm, Fire Alarm
Alarm Temperature	80 °C (-40~150 °C)
Alarm Concentration	CO

2.5.9.2.6 Inlet and exhaust valves

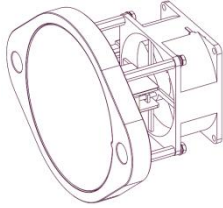
Inlet and exhaust valves	Technology contents	Parameters
	Travel distance	30 mm
	Exhaust value	> 35000 L/min
	Start Speed	4 mm/s
	Working Voltage	24 VDC
	Noise	<60 dB
	Fan rated Current/Voltage	24V/1.35A
	IP Level	IP66
	Rated power	37 W

3 Product Lifting, Transport, Storage

 **DANGER**

- Prohibition of rough loading and unloading, as this may result in short-circuiting, damage, fire or explosion of the battery.

3.1 Hoisting Operation

3.1.1 Safety Precautions for Hoisting Operations

- Throughout the entire hoisting process, it is essential to strictly follow the safety operating procedures of the crane.
 - Within a 10-meter radius of the operating area, no one is allowed to stand, especially under the crane arm and directly below any lifted or moving machinery, to prevent accidents and casualties.
 - In case of adverse weather conditions, such as heavy rain, fog, or strong winds, hoisting operations should be halted.

3.1.2 Preparations Before Hoisting

- Crane Preparation: The total weight of the equipment (including packaging) is about 3 tons, please select the crane lifting tonnage according to the total weight of the equipment and the site conditions, recommended tonnage: 5 to 8 tons.
 - Tool Preparation: Wire rope, buckles, brace, etc.

3.1.3 Hoisting Process

- The hoisting process must be carried out strictly in accordance with the hoisting diagram. For

specific details, please refer to the attached Fig. 3-1 below.

- Lifting should be done vertically, and it is prohibited to drag on the ground or to push and drag across any surface.
- After the cabinet is lifted 300mm off the ground, the movement should be paused to inspect the connection of the lifting gear. Only after confirming that the connection is secure, then continue with the lifting process.
- Throughout the entire hoisting process, it should be carried out slowly, with careful observation of the box's balance. The movement must not be too fast.

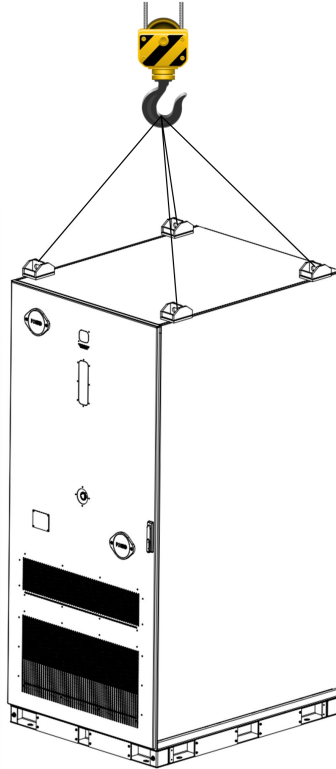

Fig. 3-1 Lifting Schematic

3.2 Forklift Operation

When conducting forklift operations with a forklift, the following conditions must be met:

1. The forklift used should have adequate load capacity (it is recommended to have at least 5 tons).
2. When using a forklift for lifting operations, the fork should be fully inserted into the entire depth of the energy storage cabinet, with the fork length being no less than 1500mm. As shown in Fig. 3-2 below:

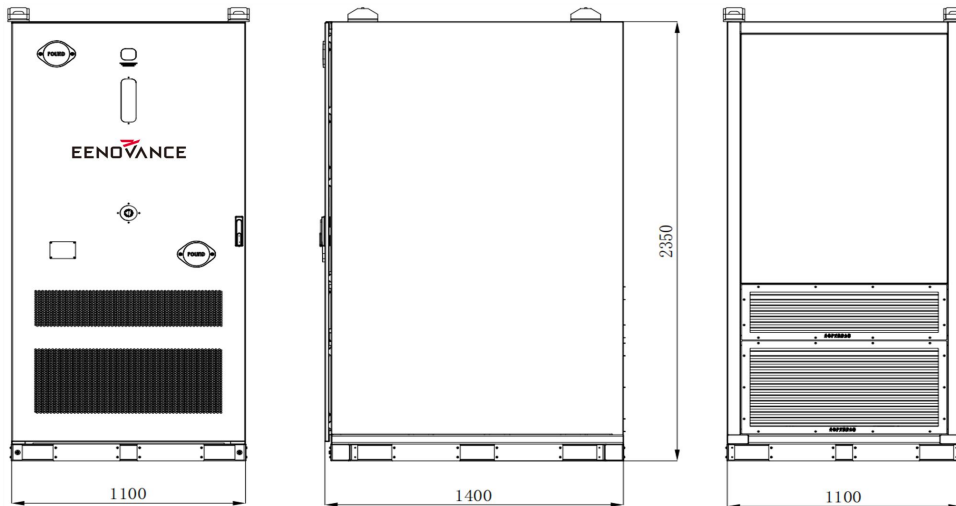

Fig. 3-2 Forklift Hole Diagram

3. During the movement, make sure that it is slow and smooth, and a test fork must be performed.
4. For safety considerations during forklift loading, it is recommended that a safety belt be tied around the energy storage cabinet and attached to the forklift crossbar. For specific forklift operations, refer to Fig. 3-3 below.

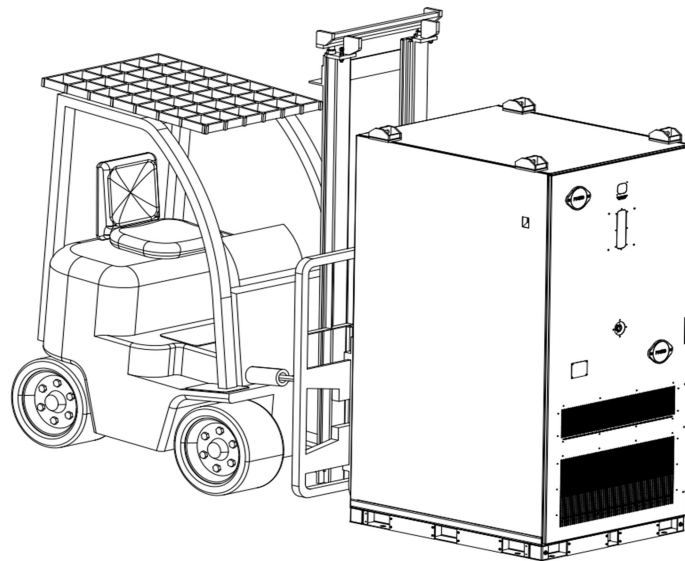

Fig. 3-3 Fork Diagram



- Always keep in mind the mechanical parameters of the energy storage system during transportation and handling
- Dimension (W*D*H):1100*1400*2350 mm
- Weight: about 3500kg

4 Equipment Installation

4.1 Installation Precautions

4.1.1 Installation Requirements

- Be careful not to touch the staff when the cabinet is lifted to the ground.
- Specialized installation isolation areas are required to perform installation operations.
- During the lifting process, pay more attention to the energy storage cabinets to be held lightly.
 - Installation should only be carried out by installers trained in high voltage electrical handling.
 - Do not install the energy storage cabinet if it is defective, cracked or damaged.
 - Do not attempt to open, disassemble or modify the energy storage cabinet during installation.
 - Do not install in inclement weather such as rain, sand, etc..
 - To protect the Energy Storage Cabinet and its components from damage during transportation, do not hit, drag or step on the Energy Storage Cabinet, and do not subject the Energy Storage Cabinet to any strong external force.
 - Do not insert foreign objects into any part of the energy storage cabinet.
 - Do not expose the energy storage cabinet or its components directly to flames.
 - Do not install energy storage cabinets near heating equipment.
 - Do not immerse the Energy Storage Cabinet or its components in water or other liquids.
 - Please place the energy storage cabinet on a level floor and make sure that it is placed smoothly without wobbling or tilting.
 - The installation of energy storage cabinets should take into account the bearing and loading capacity of the ground on which they are installed.

4.2 Pre-installation

4.2.1 Installation Environmental Requirements

Considering the space requirements of the energy storage battery storage cabinet, the specific installation distance is based on the requirements of local design and installation specifications.

NOTICE

- The maintenance space of the front door of the cabinet is required to be not less than 1.5m (if a forklift is needed to replace the pack, it is recommended to reserve 2.5m).
- The maintenance space on the left and right sides is required to be not less than 0.2m.
- The maintenance space of the back door of the cabinet is required to be not less than 0.6m.
- Environment Humidity: 0~95 °C. non-condensing.
- Altitude: 4000m (>2000m derating).

Refer to Fig. 4-1 below for a diagram of the minimum dimensions for the installation and operation and maintenance of energy storage cabinets:

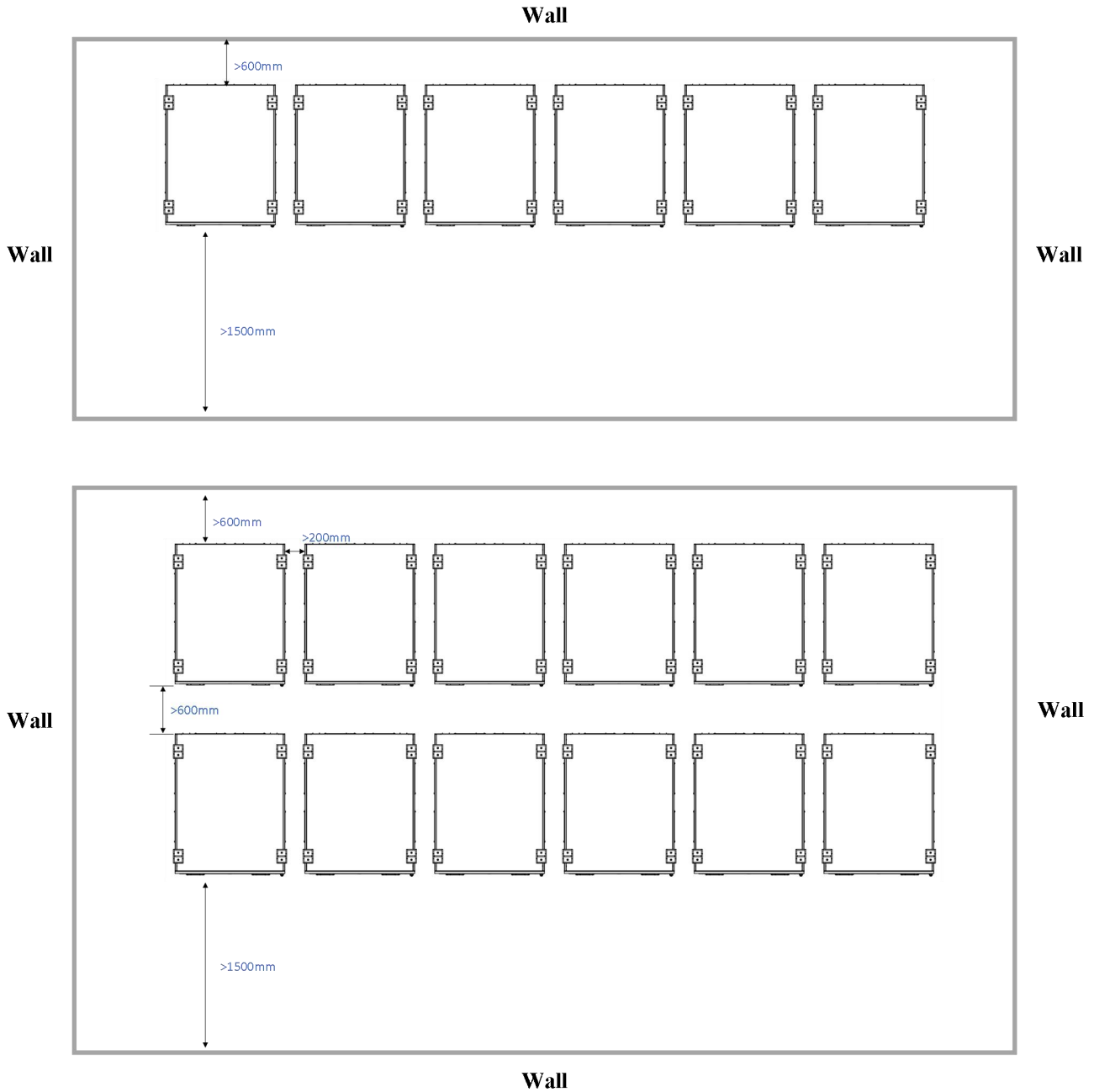

Fig. 4-1 Installation Site Requirements

4.2.2 Foundation requirements

1. The installation level should be higher than the highest water level in the history of the area and at least 200mm higher than the horizontal ground, and the installation position should not be in low-lying areas. The installation site should have a dry climate, good ventilation, and be located away from areas prone to fire or explosion hazards.
2. The energy storage cabinet must be mounted on concrete or other non-combustible surfaces, and the mounting plane must be level, firm, and flat, with sufficient bearing capacity to prohibit depressions or tilting.
3. The foundation soil needs to have a certain degree of compactness, and it is recommended that the relative density of the soil at the installation site is not less than 98%. If the soil is loose,

corresponding measures must be taken to ensure the stability of the foundation. The equipment foundation is configured according to the total weight of the equipment, if the foundation capacity is not satisfied, it needs to be reviewed.

4. Equipment foundation excavation is strictly prohibited after soaking water disturbance, if soaking water disturbance should continue to excavate and replace the fill.
5. Equipment foundation and cabinet contact surface level error less 3m.
6. Construction of drainage facilities in conjunction with local geology and municipal supporting drainage requirements to ensure that water does not accumulate at the foundation of the equipment. foundation construction should meet the local historical maximum rainfall drainage requirements, and the discharged water needs to be treated in accordance with local laws and regulations.
7. When constructing the equipment foundation, it’s important to consider the energy storage cabinet cable outlet and reserve a trench or inlet hole. The trench must incorporate necessary waterproof and moisture-proof designs to prevent cable aging and short circuits, which could affect the normal operation of the energy storage equipment. Due to the high power of the equipment and the correspondingly thick cables required, the design of the trench must take into account the cross-sectional area of the cables adequately.
8. The holes reserved for the foundation of the equipment and the holes for the inlet lines at the bottom of the equipment shall be blocked.
9. Customers can determine the number of cables supports based on their needs, and the cable supports must fully consider the weight and size of the equipment. When laying cables, communication lines, power lines, and power cables need to be laid separately. Direct current circuits and alternating current circuits should be laid separately, and the distance between different cables should be greater than 300mm.
10. Site Location Requirements. The area where the equipment is placed should be firm, level, well drained, and free of obstructions or protrusions.

4.2.3 Equipment Ventilation Requirements

The operation of energy storage equipment generates a large amount of heat, and high equipment temperatures can cause deterioration of the electrical parameters of the energy storage equipment and may cause damage to the energy storage equipment. To ensure the heat dissipation of the energy storage device, the installation environment must meet the following requirements:

1. The equipment should be installed in a well-ventilated environment.
2. The air inlet must ensure that enough fresh air enters into enters.
3. The ventilation system for the equipment is recommended to be separate from the rest of the ventilation system in the control room.
4. If the equipment overheats, check whether the air vents are properly ventilated.

4.2.4 Installation Tool Preparation

Table 4-1 Tool Preparation

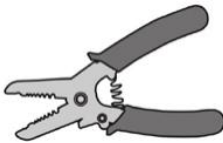
Tool	Quantity	Illustrative Diagram
Wire Stripper	1	

Electric Forklift Truck

1

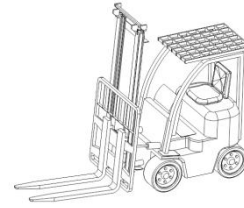

Multimeter

1



Torque Wrench

1



Insulated Socket Wrench

1



TweeZers

1

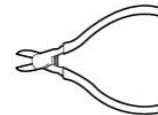

Heat Gun

1



Hand Forklift

1



Pneumatic Drill

1

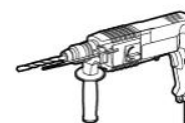

Art Knife

1



Safety Gloves

1



Protective Glasses

1



Insulating Shoes

1



Safety Helmet

1

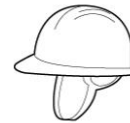

4.2.5 Pre-installation Inspection

Table 4-2 Inspection items

No.	Inspection items
1	Check that the packing boxes are not missing, damaged, or damp
2	After unpacking, please check the shell of each module without deformation, paint loss, rupture and other abnormalities, and no water damage and other abnormalities in the shell.
3	Please check the contents of the box for accessories and count the items according to the list to ensure that they are complete (optional).

4.3 Energy Storage System Structure Installation

4.3.1 Cabinet Package Removing & Installation

Step 1: Remove the outer box packaging

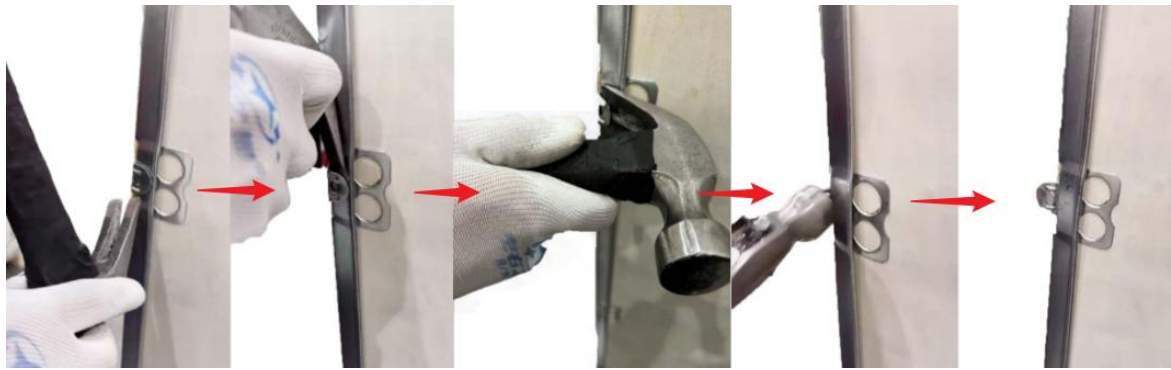

Fig. 4-2 Schematic Diagram of the Removal of the Wooden Box

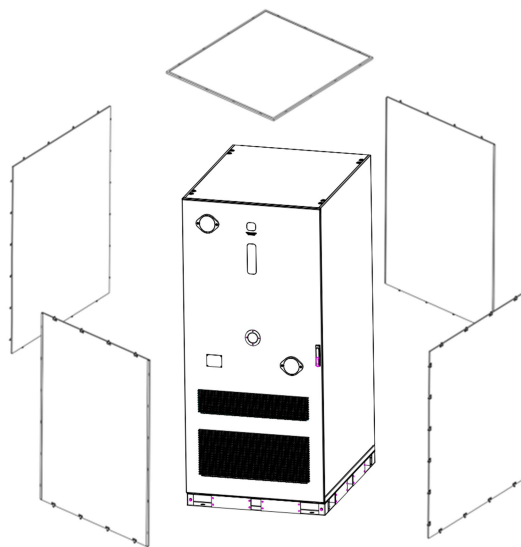

Fig. 4-3 Removing around Box Graph

Step 2: Remove the pallet by removing the bolts connecting the energy storage system to the pallet with an adjustable wrench or socket wrench

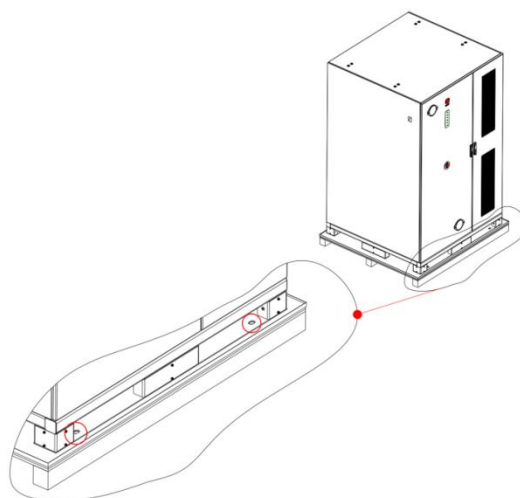

Fig. 4-4 Partial Screw Removal Diagram

Step 3: Remove the sealing plate of the cabinet base, use a Phillips screwdriver to remove the sealing plate of the base

Step 4: Open the cabinet door

Step 5: Pick up the information for the file box, such as packing list, etc.

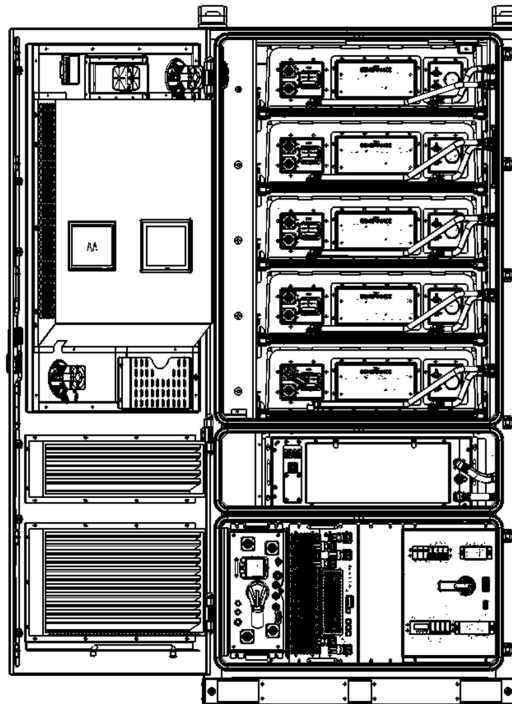
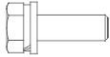



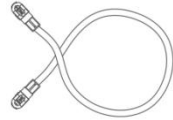
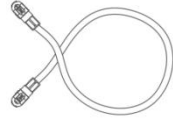

Fig. 4-6 Opening door Schematic

Step 6: Take out the installation parts supplied with the box, after opening the door, please check the delivery parts and quantity supplied with the box according to the “packing list” . As following table:

Table 4- 3 Inspection items

Name	Description	Quantity	Illustrative Diagram
Bolt	/	45	
Ring Screw	/	8	
Power Cable 1	PDU B- To 1#Pack B-	1	
Power Cable 2	1#Pack B+ To 2#Pack B-	1	
Power Cable 3	5#Pack B+ To 6#Pack B-	1	
Power Cable 4	11#Pack B+ To PDU B+	1	

FPC Adapter Cable 1 / 1



4G Antenna 1 / 1



Step 7: After closing the cabinet door, move the energy storage cabinet to the designated installation location. When using a forklift to move the equipment, please tie down and fix it according to the actual situation to ensure that there is no risk of tipping over. When using a hoist to move the equipment, use a nylon sling (strap) or wire rope

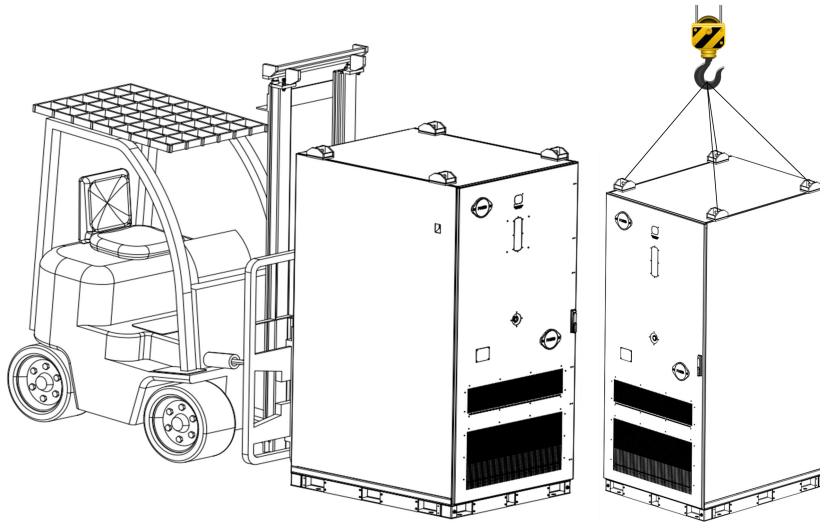

Fig. 4-7 Transportation Schematic

Step 8: Fixing the energy storage system

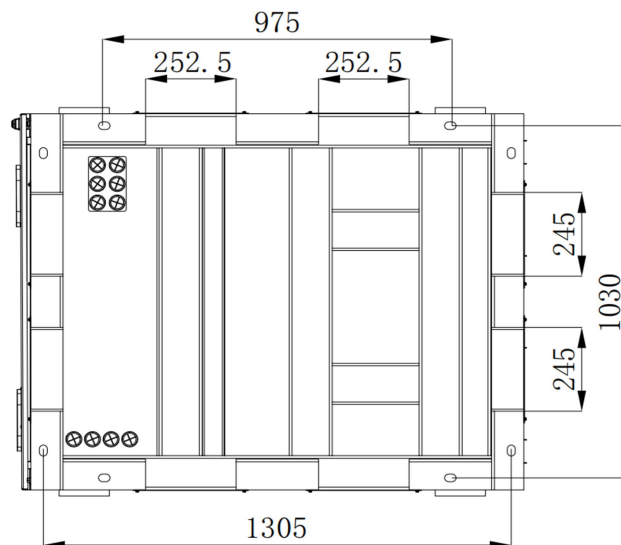

Fig. 4-8 Fixing Schematic

4.3.1 Pack Installation in Cabinet

1. Pre-installation Inspection

NOTICE

- Please make sure that the installed battery Pack is intact.
- Before installation, please consult the information on installing the battery Pack, and familiarize with and comply with its installation requirements and precautions.

2.Procedure

The battery pack is installed in the energy storage cabinet, . As following Fig. 4-9:

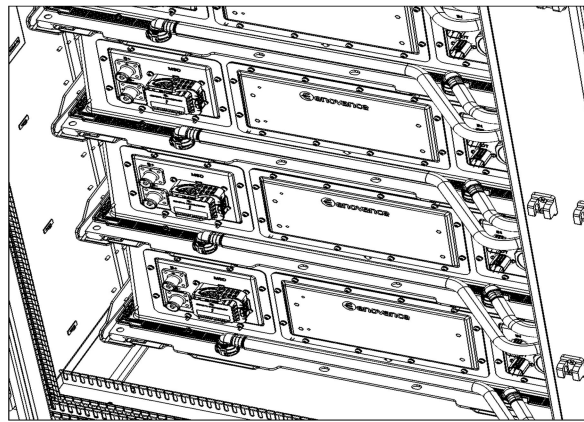

Fig. 4-9 Pack Installation Diagram

4.3.2 Structure Safety Check

Table 4-4 Safety Check





No.	Inspection Items	Treatment Measures
1	Fasteners are tightened or not	If loose, tighten the screws again
2	Whether the space environment meets the installation size requirements	If space is insufficient, it is recommended to redesign and reinstall
3	Are the air ducts clear and free of foreign objects	If there is a foreign body, please deal with it, if it does not flow smoothly to rule out the causes

4.4 Energy Storage System Electrical Connection

The internal work of the energy storage cabinet has been completed before delivery except for the wiring between battery packs, the user only needs to connect the inter-cabinet cable and external wiring can be, the AC terminal is mainly located in the lower right side of the energy storage cabinet, the ground terminal is located in the bottom of the energy storage cabinet.

4.4.1 Energy Storage System Interface Description

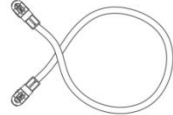
It's necessary to connect cables between battery packs in the energy storage cabinet, as shown in the following figure

Name	Description	Quantity	Illustrative Diagram
Power Cable 1	PDU B- To 1#Pack B-	1	
Power Cable 2	1#Pack B+ To 2#Pack B-	1	
Power Cable 3	6#Pack B+ To PDU B+	1	
FPC Adapter Cable 1	/	1	
4G Antenna	/	1	

Step1:

Take the four power harnesses and install them in a position as shown in the figure below, such as pressing the harness connections into place and hearing a “click” that is, the installation is in place

Step2:

Take the harness 5 and install it in the Fig. 2 position, plugging it in power cables connecting the energy storage cabinet to the power grid, this part of the cable to be provided by the customer, as shown in the following figure:

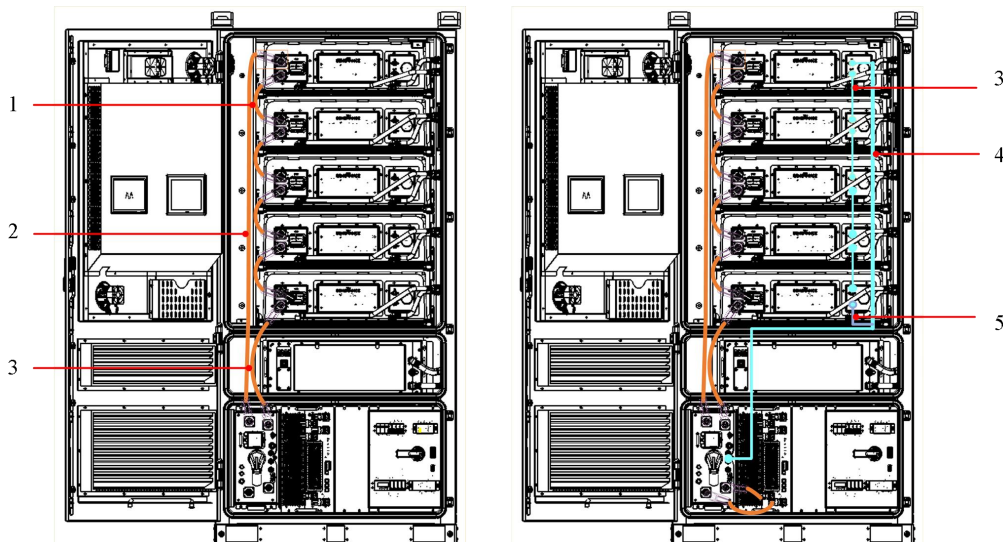

Fig. 4-10 Connect Cables between Battery Packs Diagram

Step3:

Take the 4G antenna and bring it inside the cabinet from the left side of the cabinet through the threading hole, then place it on the top of the cabinet as shown in the figure below:

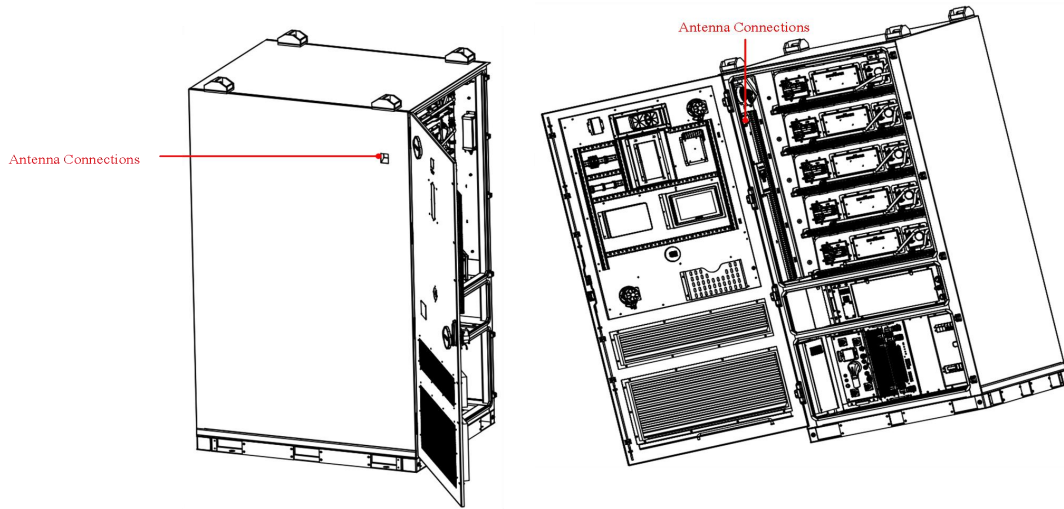

Fig. 4-11 Power Cables Diagram

Step4:

After crimping the external connection cable A/B/C phase to OT70-10 terminal) and N wire to OT70-6 terminal, lock it in the position as shown below(M10: 21N.m. M6: 5N.m) power cables connecting the energy storage cabinet to the power grid, this part of the cable to be provided by the customer, as shown in the following Fig.4-12

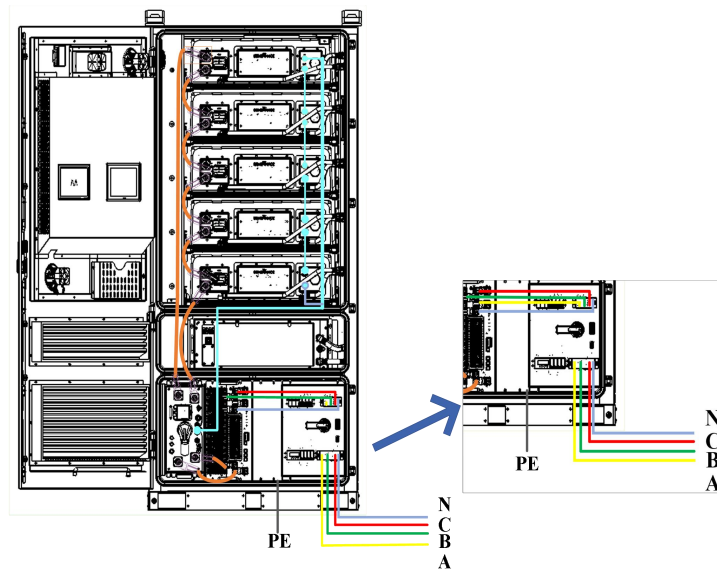

Fig. 4-12 Connect Cables to Grid

4.4.2 Wiring Description Sheet

Connect cables requirements between battery packs in the energy storage cabinet, as shown in the following Table 4-5

Table 4-5 Wiring Description Sheet

No	Name	Cable Specifications	Terminal	Clarification
----	------	----------------------	----------	---------------

Specifications				
1	A Phase	70 mm ²	M10(OT terminal)	Connecting cables between the cabinet and the external power grid
2	B Phase	70 mm ²	M10(OT terminal)	Connecting cables between the cabinet and the external power grid
3	C Phase	70 mm ²	M10(OT terminal)	Connecting cables between the cabinet and the external power grid
4	N Phase	35 mm ²	M10(OT terminal)	Connecting N phase
5	PE	35 mm ²	M6(OT terminal)	Connecting Earth



• **Note:** The external AC side connection to the grid requires customers to prepare their own cables. The grounding wire must be securely grounded.

4.5 Electrical Wiring

4.5.1 External AC Cable Connection and Procedure

1. Before electrically connecting the energy storage cabinet, it is essential to ensure that the power grid and the cables are in a completely de-energized state, and the AC circuit breaker should not be closed before the electrical connection is completed.
2. Use a wire stripper to strip the corresponding specification ground wire to expose a bare copper core, and the length of the bare copper core should be 3mm longer than the OT terminal connection end.
3. Use a crimping tool to crimp the OT terminal onto the bare copper core.
4. Slide a heat-shrink tube of the appropriate size onto the wiring end of the OT terminal, and the length of the heat-shrink tube (with a voltage rating of at least 1000V) should be 1.5 to 2 times the length of the wiring end.
5. Use a heat gun to shrink the heat-shrink tube tightly, ensuring it grips the terminal and the cable securely, thus completing the cable assembly.
6. Secure the prepared cable at its interface with the corresponding screws (use M10 screws for phases A, B, and C, and M6 screws for phase N and PE).
7. Wiring complete.

4.5.2 Checking the Equipment After Wiring

After completing the wiring, it's necessarily to carefully check whether the phase sequence and the silkscreen correspond to each other, and whether the wiring of the Zero row and the ground row is correct.

The connection diagram is as follows:

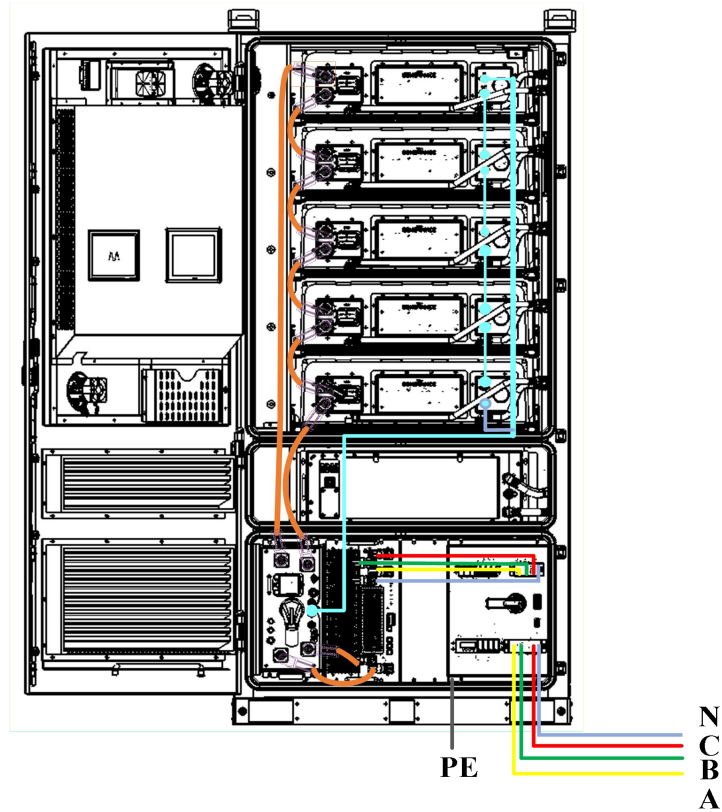

Fig. 4-13 Overview of All Connection Diagram

5 Product Operation

5.1 Energy Storage System Power-up Process

5.1.1 Pre-power-up Check

- Check that the circuit breaker in the electrical compartment inside the storage cabinet is in the disconnected position.
- Check whether the serial power cables between the battery packs and between the battery packs and the high voltage box are connected reliably.
- Check that all communication and power supply cable connection terminals are connected reliably and that the grounding cable is reliable.
- Check that the communication and power harnesses as well as the power cables are properly connected on the high voltage box panel.
 - Check that the emergency stop button is released.
 - Use a multimeter to check that the DC and AC voltages meet the startup conditions and ensure that there is no overvoltage.
 - Check and make sure that there are no unnecessary tools and devices inside the equipment.
 - Check all air inlets and outlets for blockages.

5.1.2 Power-up Procedure

Table 5-1 Power-up Procedure Steps

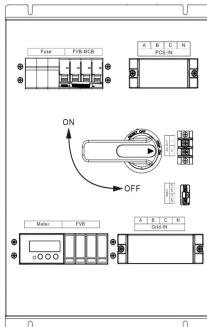
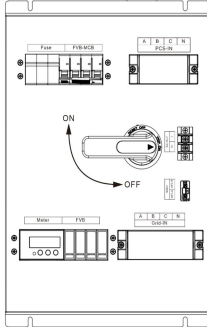
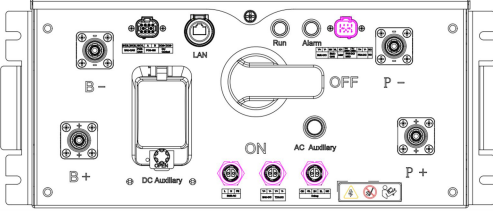
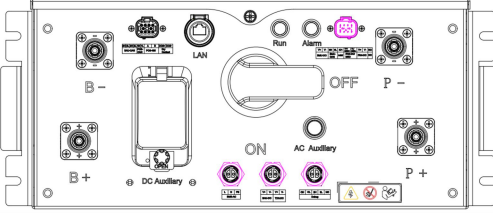
Steps	Check Lists	Status
Step 1	<p>Check that the Liquid cooling unit, HV box, Lamp, and FVB switches are in the disconnected state, close the main switch for the grid on the distribution box, then observe the meter display information which should be 400 ± 20 V.</p>	
Step 2	<p>Close the auxiliary power MCB Liquid cooling unit, HV box, Lamp, FVB on the power distribution as picture shows, box in the energy storage cabinet, then the lamp will be bright, Liquid cooling unit running, and PCS light on.</p>	
Step 3	<p>After closing the 220V power supply circuit breaker of the HV box, press the HV box start button. The fault indicator light of the HV box lights up. Close the circuit breaker of the HV box, and the fault light goes out while the operation light flashes. The main circuit relay of the HV box automatically closes, the fault light goes out, and the operation light remains on.</p>	
Step 4	<p>Close the main circuit breaker switch on the HV box and wait for the system to finish going to high voltage Check the status of subsystems such as battery, PCS, battery, air conditioning, fire protection/IO, etc. through the local EMS display screen. The system is normal and the indicator light of the cabinet is yellow (no fault status).</p>	
Step 5	<p>Click the PCS power-on button on the EMS display screen and set the charging and discharging time periods. For details, please refer to 5.2.2 and 5.2.4.</p>	<p>/</p>

WARNING

- Please follow the steps strictly to power up
- If there is any abnormality, power down and check carefully step by step

5.1.3 Power Shutdown Procedure

WARNING

- The system needs to be powered off on both AC and DC sides to ensure personal safety when it is not operating for a long time or during installation and maintenance.

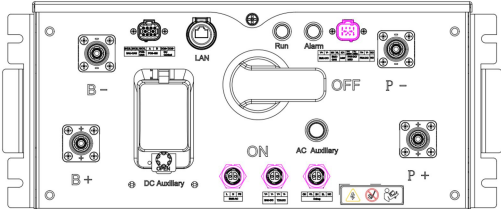
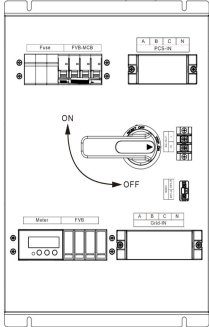
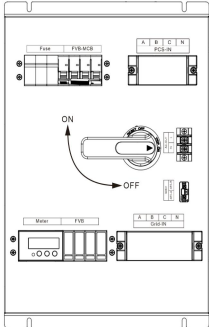
Steps	Check lists	Status
<p>Step 1</p>	<p>Ensure that the system is not in a charged or discharged state, turn off the PCS and cut off the HV box relay through EMS. see section 5.2.3 for details. Then disconnecting the hand operated circuit breaker switch on the high voltage box and pressing the HV box power switch QF.</p>	
<p>Step 2</p>	<p>Disconnect the auxiliary power miniature circuit breakers (MCB) QF2, QF3, QF4, and QF5 on the power distribution box inside the storage battery storage cabinet</p>	
<p>Step 3</p>	<p>Close the grid molded case switch QF1</p>	

5.2 EMS Interface Operation

5.2.1 EMS Interface Introduction

5.2.1.1 Overview

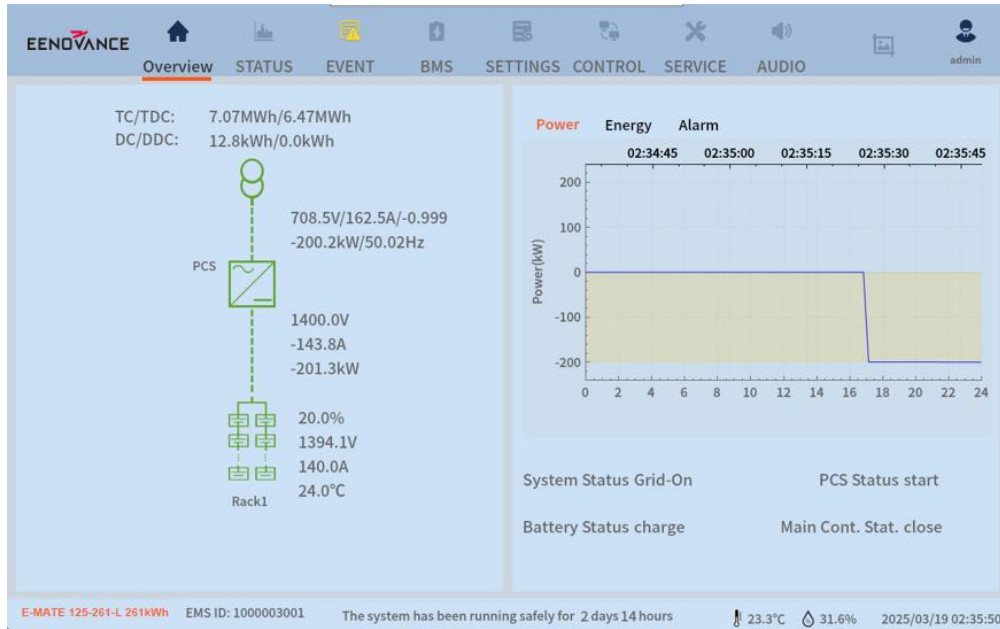

Fig. 5-1 EMS System Overview Screen

The system overview section can display real-time data such as total charging/discharging energy, daily charging/discharging energy, operational data of the PCS AC and DC sides, operational data of the battery pack, as well as the current charging/discharging power and the control strategy of the day. As shown in Fig. 5-1:

- In the energy storage system, the total charging energy (TC) is 7.07 MWh, and the total discharging energy (TDC) is 6.47 MWh.
- Daily charging energy (DC) is 12.8 kWh, and daily discharging energy (DDC) is 0.0kWh.
- Operational data of the PCS AC side: The AB line voltage is 708.5 V, current in phase A is 162.5 A, power factor is -0.999, output power is -200.2 kW, and frequency is 50.02 HZ.
- Operational data of the PCS DC side: DC voltage is 1400 V, DC current is -143.8 A, and output power is -201.3 kW.
- Battery pack operational data: Battery SOC (State of Charge) is 20.0 %, voltage is 1394.1 V, current is 140.0 A, and the average temperature of the battery cells is 24.0°C.
- The lower right corner of the picture shows the working state of the system: on grid, PCS working state: start, Battery state: charge, main contactor state: close.

5.2.1.2 EMS Status

The equipment status section displays real-time data of the system, BMS, PCS, liquid cooler, and fire protection system. As shown in Fig. 5-2.

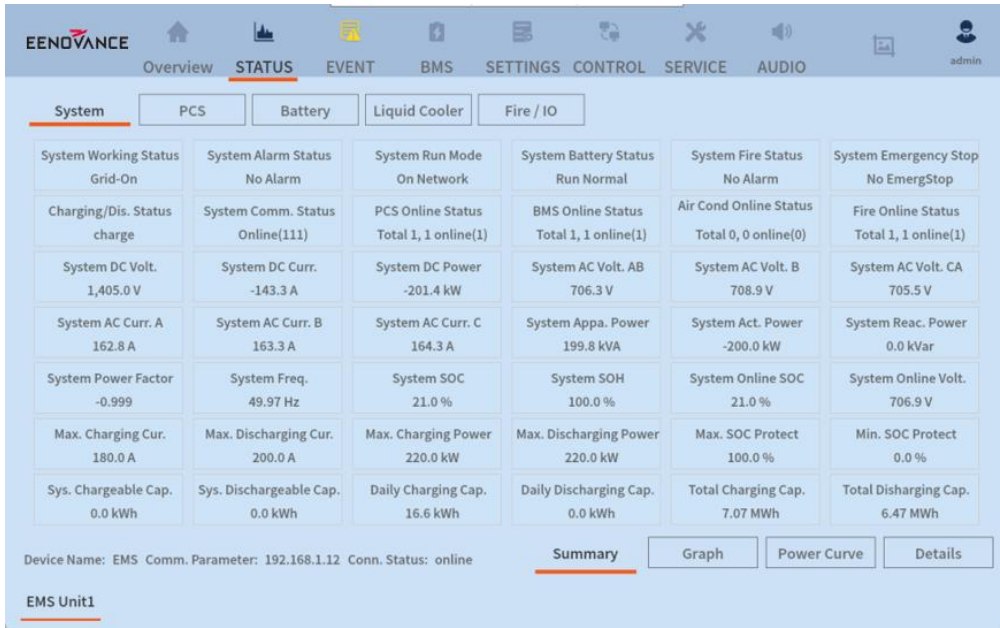

Fig. 5-2 EMS Event Logging Screen

5.2.1.3 EMS Events

The event recording section records the alarm fault information of the system and equipment, and displays the current events, historical events, events statistic, etc. As shown in Fig. 5-3.

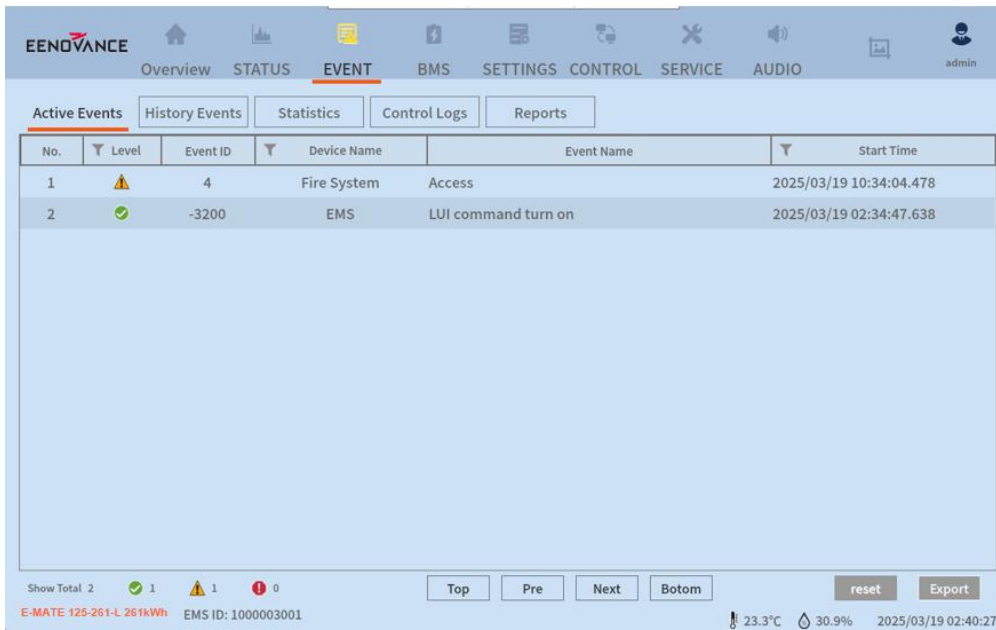

Fig. 5-3 EMS Event Logging Screen

5.2.1.4 BMS Information

The Battery Information section monitors and displays the operating status of the battery cluster in real time. As shown in Fig. 5-4:

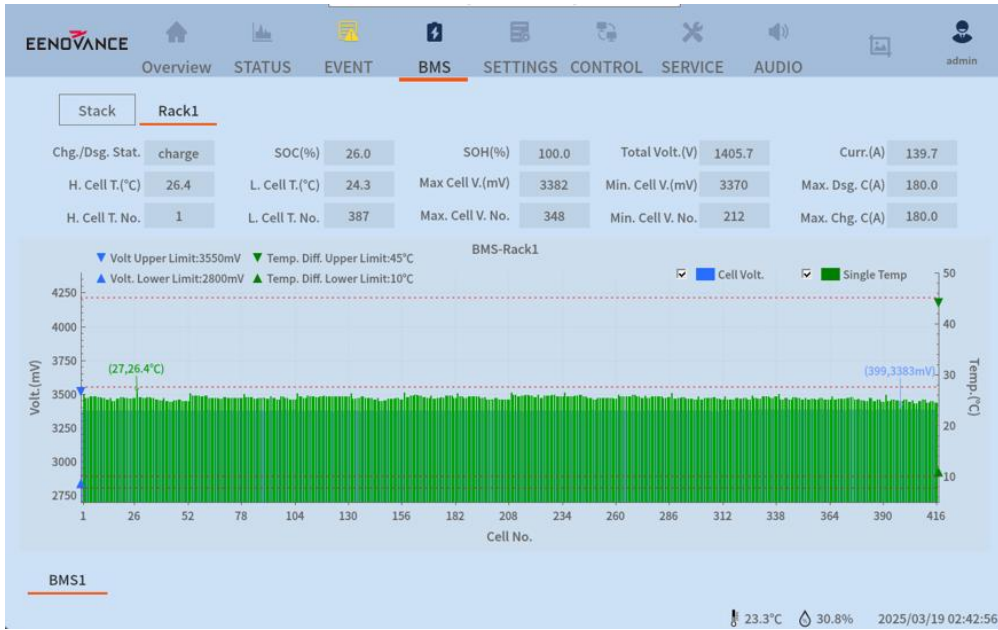

Fig. 5-4 EMS Battery Management Interface

5.2.1.5 EMS Settings

The parameter setting part provides the installed configuration and the operation configuration of the system parameters. As shown in Fig. 5-5:

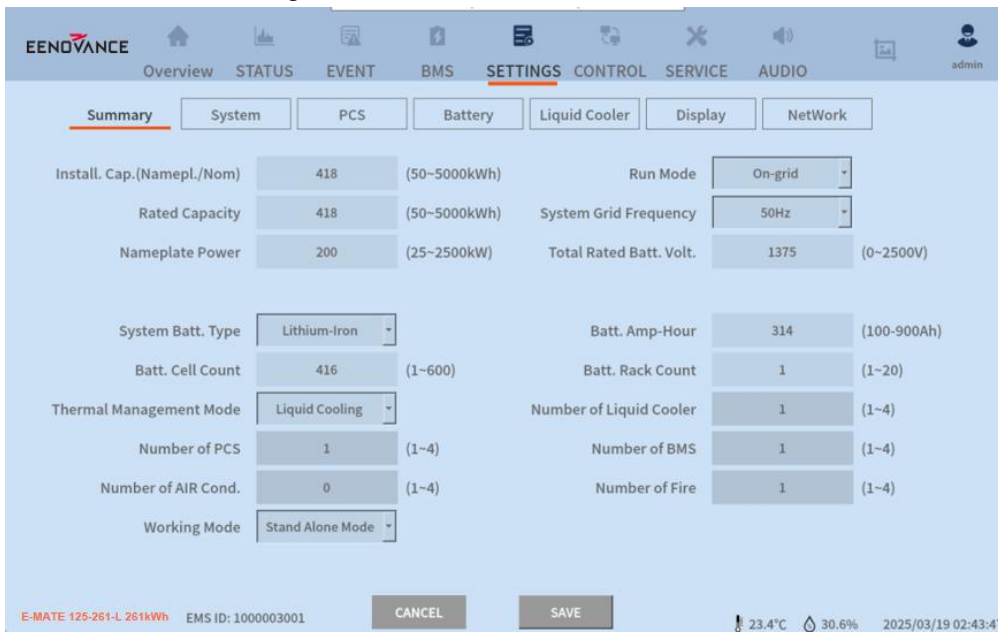

Fig. 5-5 EMS Parameter Setting Interface

5.2.1.6 Control

The control strategy partially controls the PCS on / off and the battery contactor open / close. At the same time, the control strategy of peak shaving and valley filling can also be set up. As shown in Fig. 5-6:

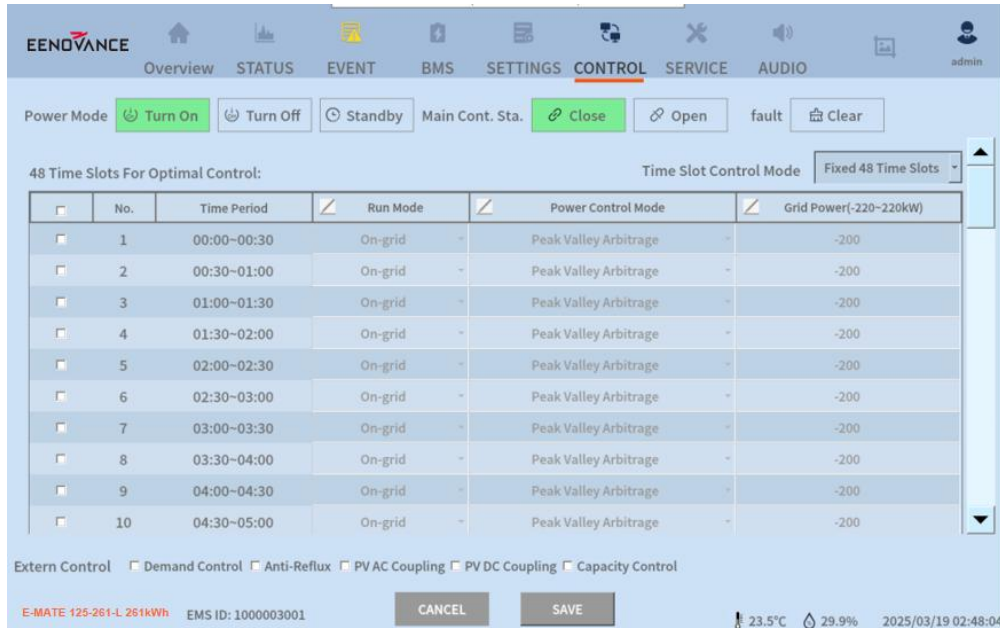

Fig. 5-6 EMS Control Strategy Interface

5.2.2 EMS Basic Setting

The EMS interface allows for control and parameter settings of various components within the energy storage system, including BMS, batteries, air conditioning, as well as PCS and network parameters, all of which can be configured through the EMS panel. Here is an introduction to the basic parameter settings for the relevant equipment:



- The energy storage system has been configured and optimized for relevant parameters at the factory. It is not recommended to modify them under normal circumstances, otherwise, the consequences will be borne by the user.
- If there are any doubts regarding the parameter settings, contact the after-sales technical support.

The parameter setting page provides the installation configuration and the operation configuration of the equipment parameters.

The Summary page provides the installation configuration. As shown in Fig. 5-7:

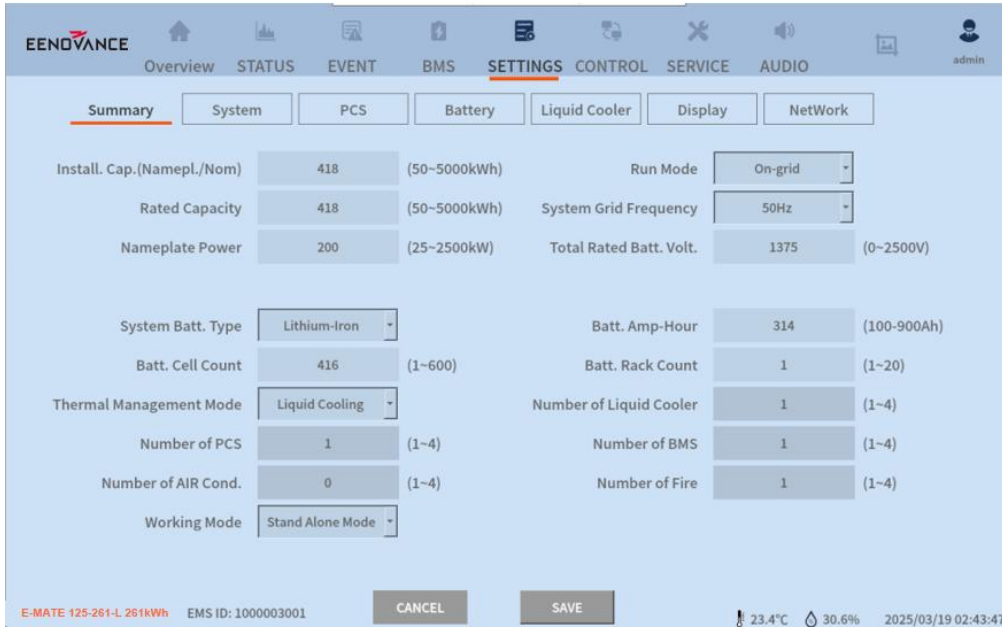

Fig. 5-7 Parameter Settings - Summary

The System page provides system-level parameter configuration. As shown in Figure 5-8 :

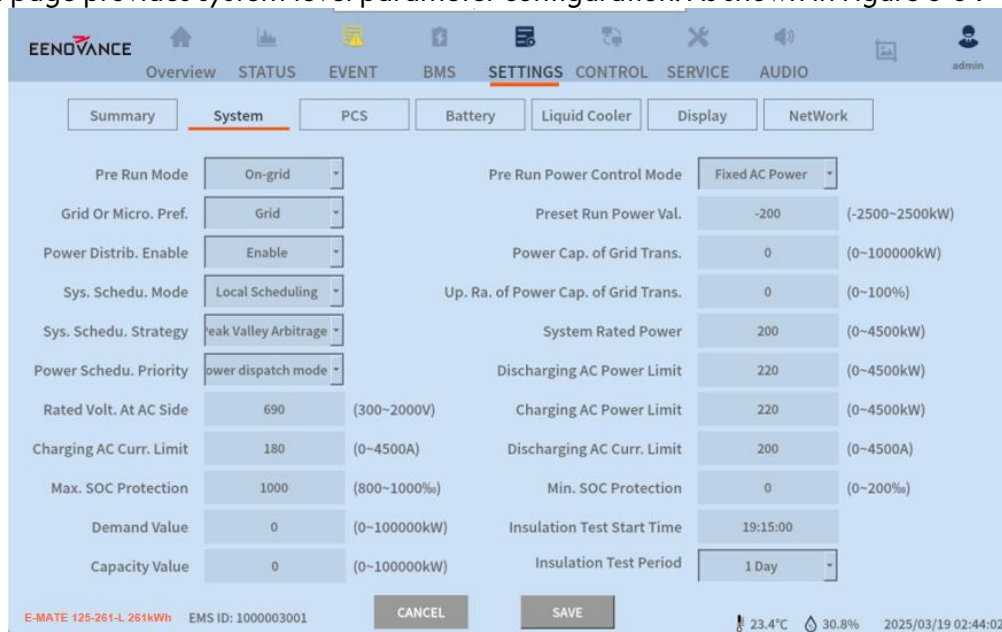

Fig. 5-8 Parameter Settings - System

The Battery page provides battery parameter settings, including battery protection strategy and alarm protection threshold settings. As shown in Figure 5-9:

EENDOVANCE Overview STATUS EVENT BMS **SETTINGS** CONTROL SERVICE AUDIO admin

Summary System PCS **Battery** Liquid Cooler Display NetWork

System SOC Protection	Disable	Total Batt. Volt. Protection	Enable	(Rated:1375V)
SOC Up. Li. Pro. L2	100 (0~100%)	To. Volt. Pro. Up. Li. 2	1560 (0~2500V)	
SOC Up. Li. Pro. L2 Reset	99 (0~100%)	To. Volt. Pro. Up. Li. 2 Reset	1539 (0~2500V)	
SOC Up. Li. Pro. L1	95 (0~100%)	To. Volt. Pro. Up. Li. 1	1539 (0~2500V)	
SOC Up. Li. Pro. L1 Reset	93 (0~100%)	To. Volt. Pro. Up. Li. 1 Reset	1518 (0~2500V)	
SOC Lo. Li. Pro. L1 Reset	10 (0~100%)	To. Volt. Pro. Lo. Li. 1 Reset	1185 (0~2500V)	
SOC Lo. Li. Pro. L1	8 (0~100%)	To. Volt. Pro. Lo. Li. 1	1164 (0~2500V)	
SOC Lo. Li. Pro. L2 Reset	5 (0~100%)	To. Volt. Pro. Lo. Li. 2 Reset	1144 (0~2500V)	
SOC Lower Limit Proc L2	4 (0~100%)	To. Volt. Pro. Lo. Li. 2	1123 (0~2500V)	
SOC Prot. Hysteresis	2 (0~5%)	To. Volt. Prot. Hysteresis	10 (0~20V)	
SOC Con. Alarm Delay TM	0 (0~60s)	To. Volt. Con. Alarm Delay TM	0 (0~60s)	

E-MATE 125-261-L.261kWh EMS ID: 1000003001 CANCEL SAVE 23.4°C 30.9% 2025/03/19 02:44:40

EENDOVANCE Overview STATUS EVENT BMS **SETTINGS** CONTROL SERVICE AUDIO admin

Summary System PCS **Battery** Liquid Cooler Display NetWork

Level1 Alarm Threshold Setting

	Alarm	Reset	Unit	Range		Alarm	Reset	Unit	Range
Cell OverV.	3500	3400	(mV)	(3400~3750)	Chg. OverT.	400	350	(0.1°C)	(350~600)
Cell UnderV.	2900	3000	(mV)	(2500~3000)	Chg. UnderT.	100	150	(0.1°C)	(-100~150)
System OverV.	14560	14360	(0.1V)	(14060~15600)	Dsg. OverT.	450	400	(0.1°C)	(350~600)
System UnderV.	12064	12289	(0.1V)	(10400~12480)	Dsg. UnderT.	50	100	(0.1°C)	(-200~100)
Chg. OverC.	1700	1600	(0.1A)	(500~2400)	Pola. OverT.	650	600	(0.1°C)	(500~1100)
Dsg. OverC.	1700	1600	(0.1A)	(500~2400)	HVB OverT.	800	700	(0.1°C)	(500~1100)
Insulation Low.	1000	1010	(Ω/V)	(100~1200)	Temp. Diff.	80	30	(0.1°C)	(30~160)
Cell Volt. Diff.	350	250	(mV)	(50~800)	SOC Low	100	150	(0.1%)	(0~1000)

Level2 Alarm Threshold Setting

E-MATE 125-261-L.261kWh EMS ID: 1000003001 CANCEL SAVE 23.4°C 30.9% 2025/03/19 02:45:28

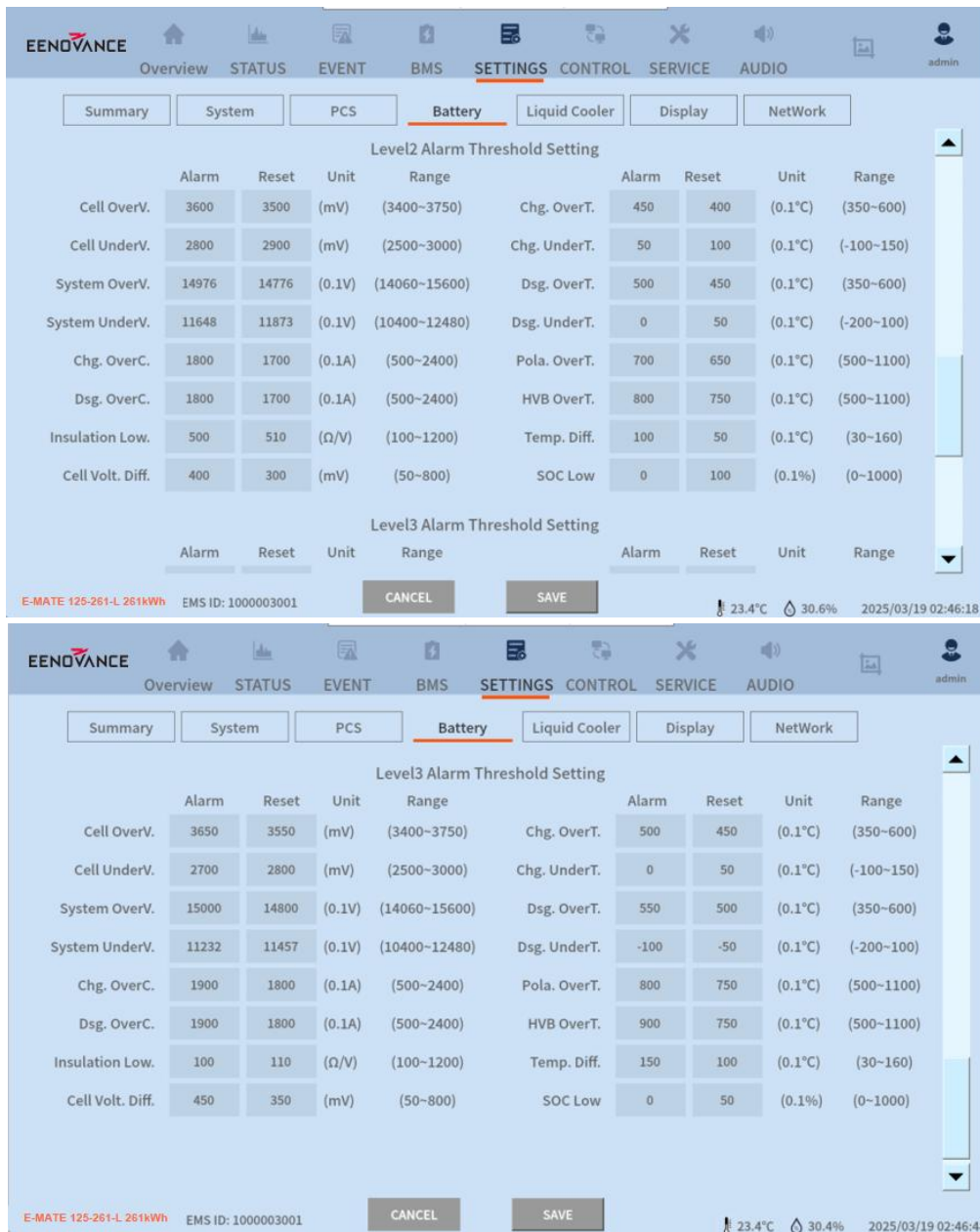

Fig. 5-9 Parameter Settings - BMS

The Liquid Cooler page provides the parameter settings of the Liquid Cooler. As shown in Figure 5-10:

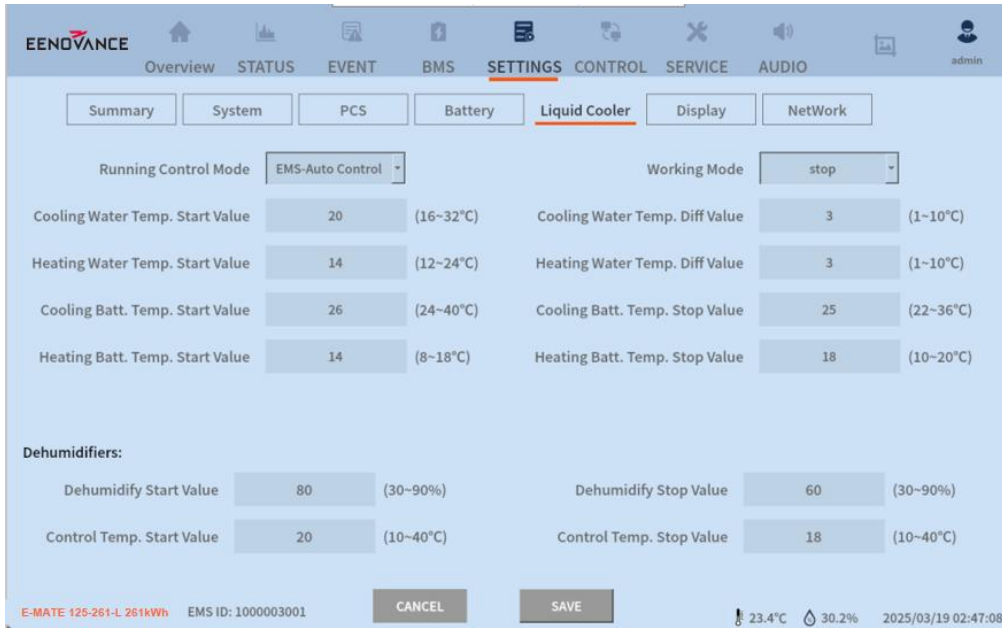

Fig. 5-10 Parameter Settings - Liquid Cooler

The Display page provides Ui display-related settings. As shown in Figure 5-11:

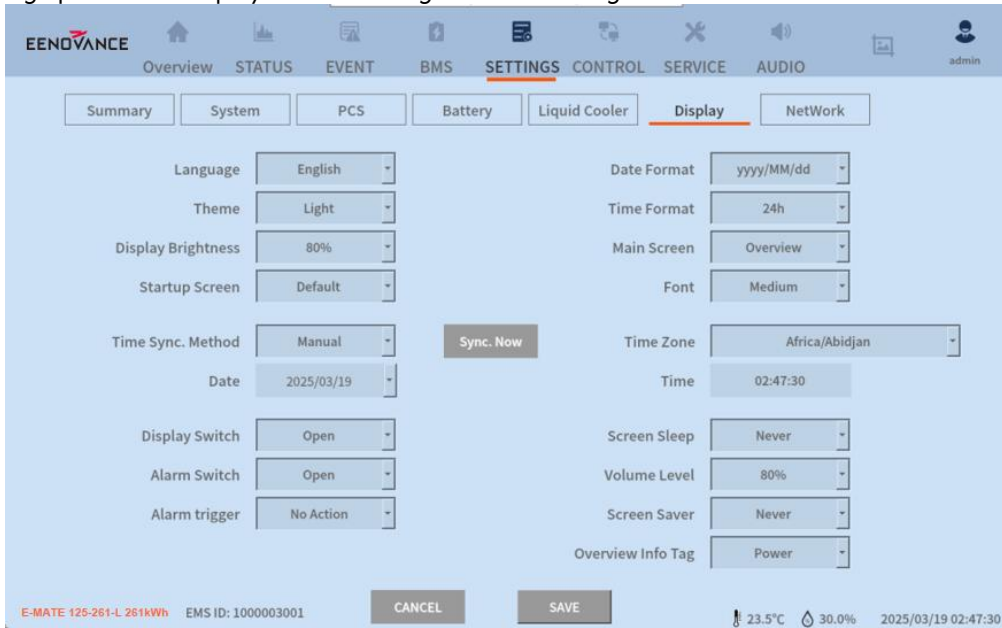
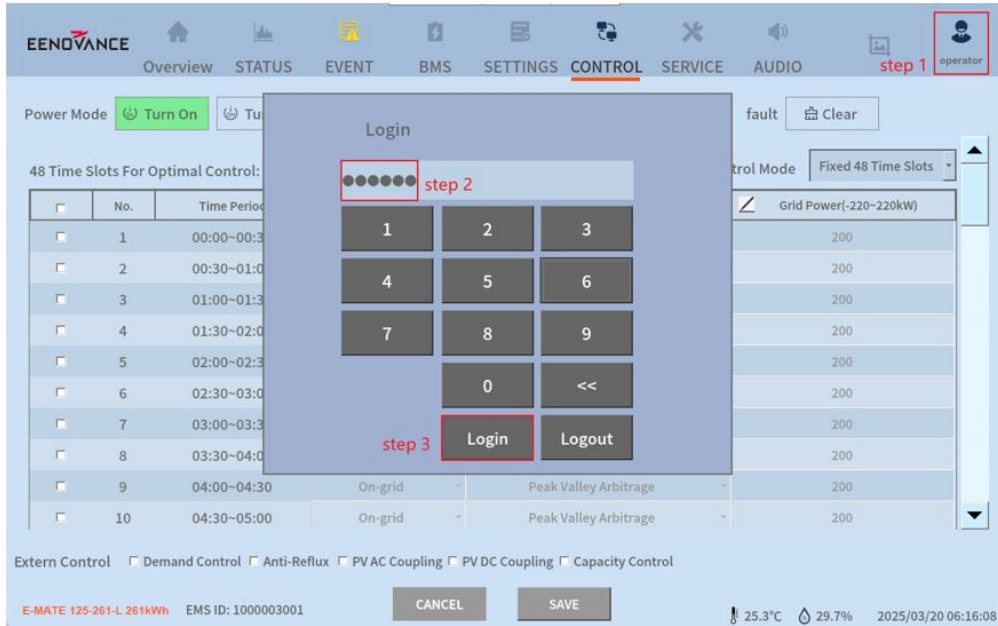

Fig. 5-11 Parameter Settings - Display

5.2.3 EMS Controlled Charge/Discharge Steps

Step 1: Log in to the EMS using the “Operator” account and password 123456.



Step 2: Ensure the system operates normally, no alarm fault. If there are faults on the Event page, first investigate the cause of the fault. For example, if the system EPO fault, first reset the EPO button, click the "Clear" button twice on the "Control Strategy" page to reset the system.

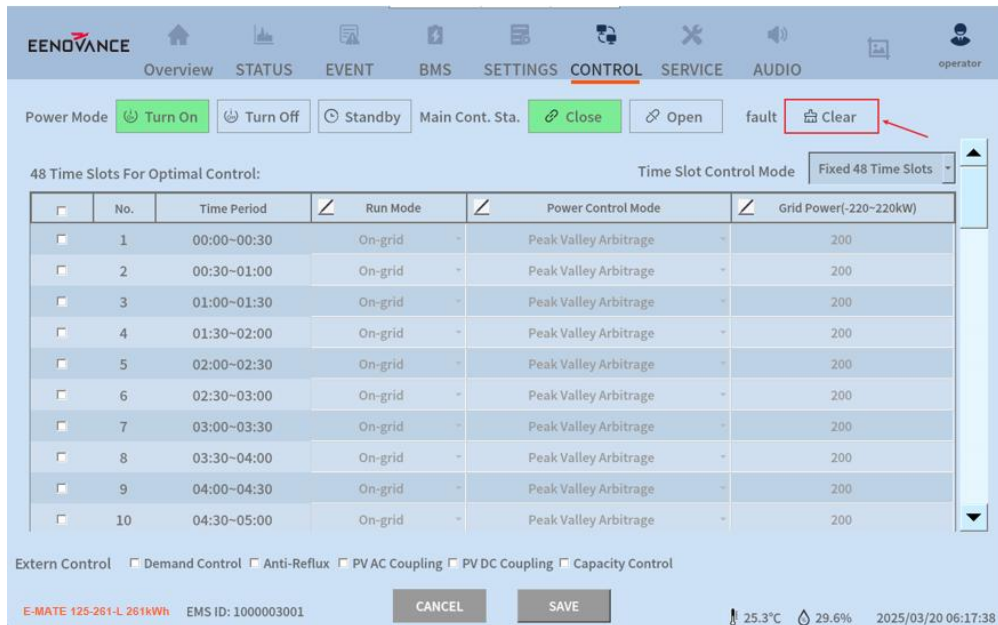

Step 3: On the Control Strategy page, set the Operation Mode to on-grid, set the Power Control Mode to Peak-Valley Arbitrage, and set the peak, valley and flat values in the Grid Power column. There are two types of setting operations, namely, setting power for a certain time period and setting power for all time periods. See Section 5.2.3 for details of the control strategy. The steps to set power for one time period are as follows:

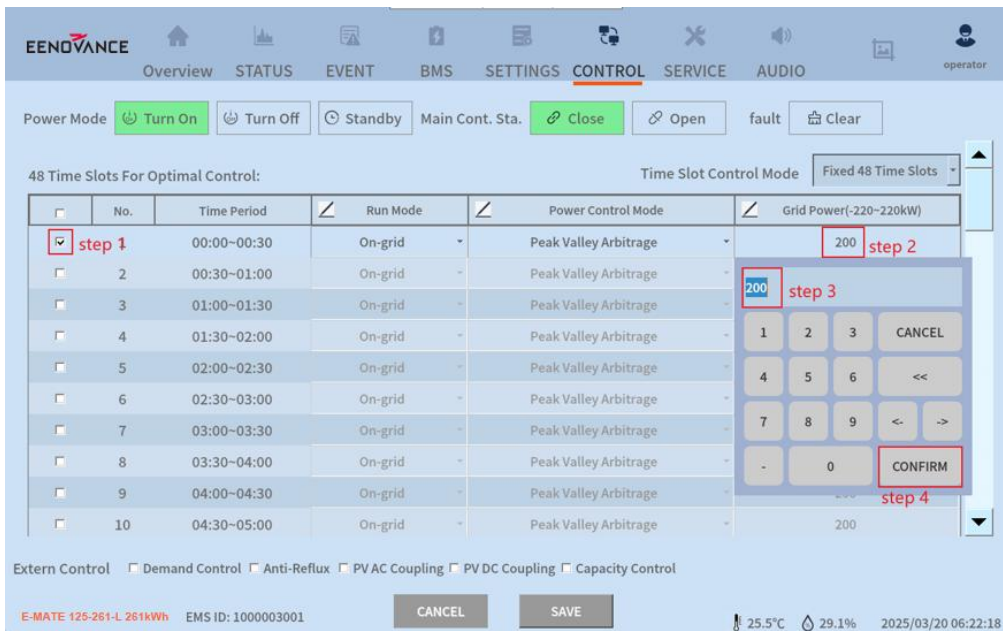

The steps to set power for all time periods are as follows:

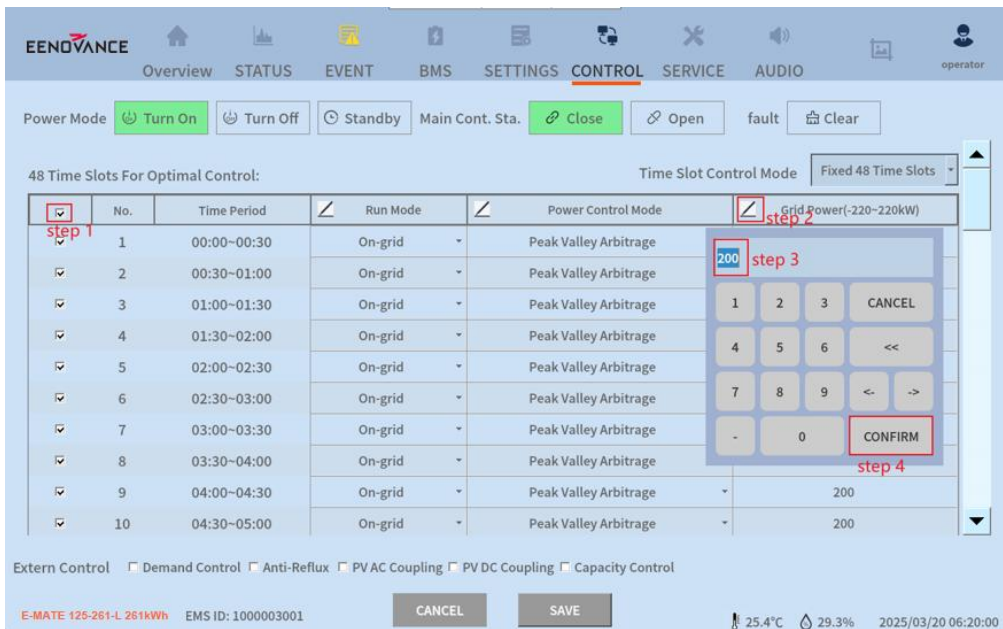

Step 4: In the “Control Strategy” page, click the “Close” button to close the main contactor.

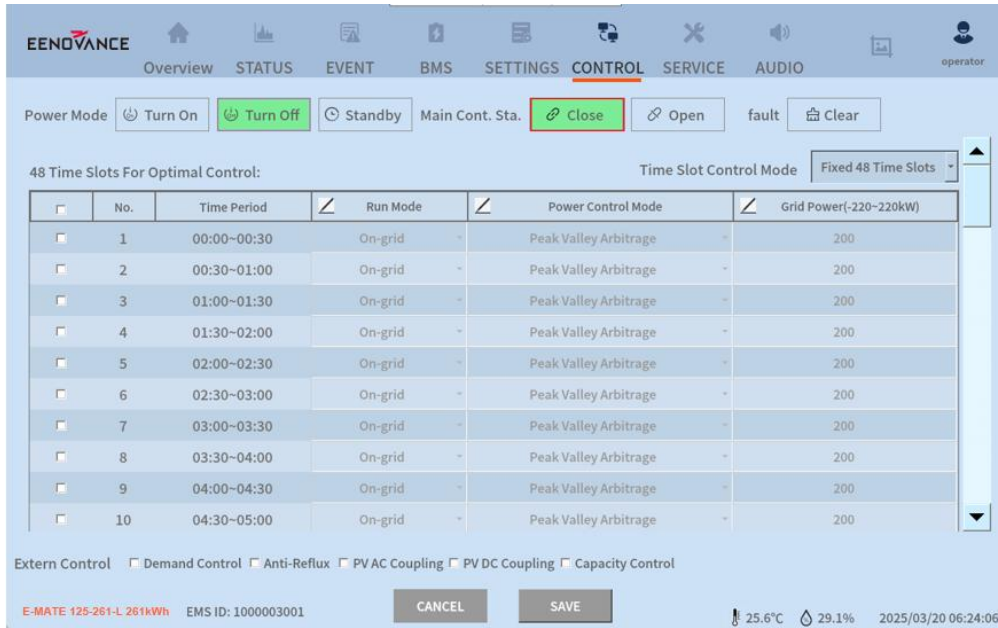

Step 5: On the “Control Policy” page, click the “Turn On” button to power on PCS.

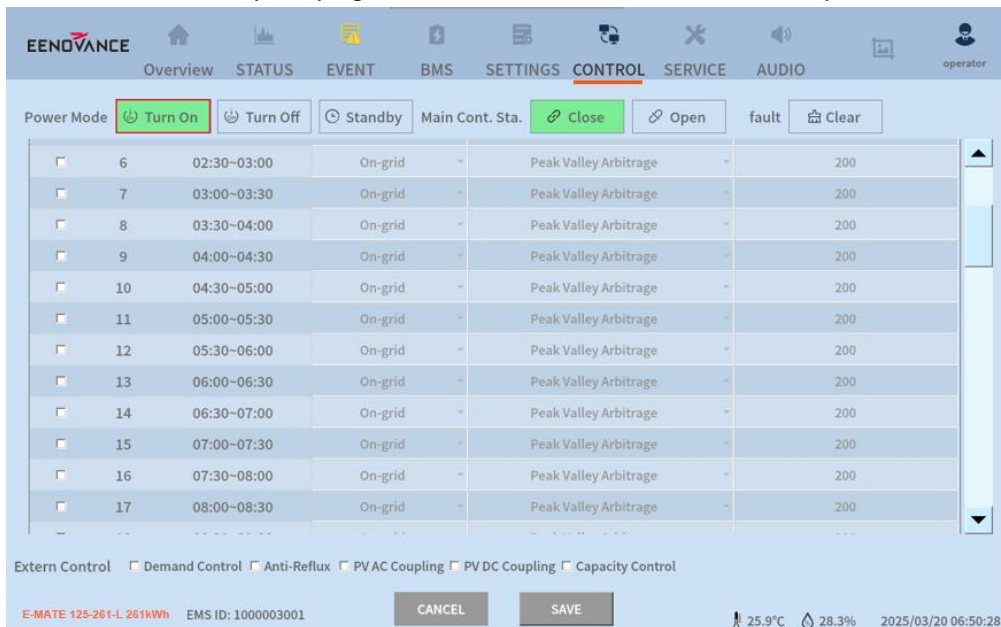

5.2.4 EMS Controlled Power off Steps

Step 1: On the "Control Strategy" page, click the "Turn off" button to shut down the PCS.

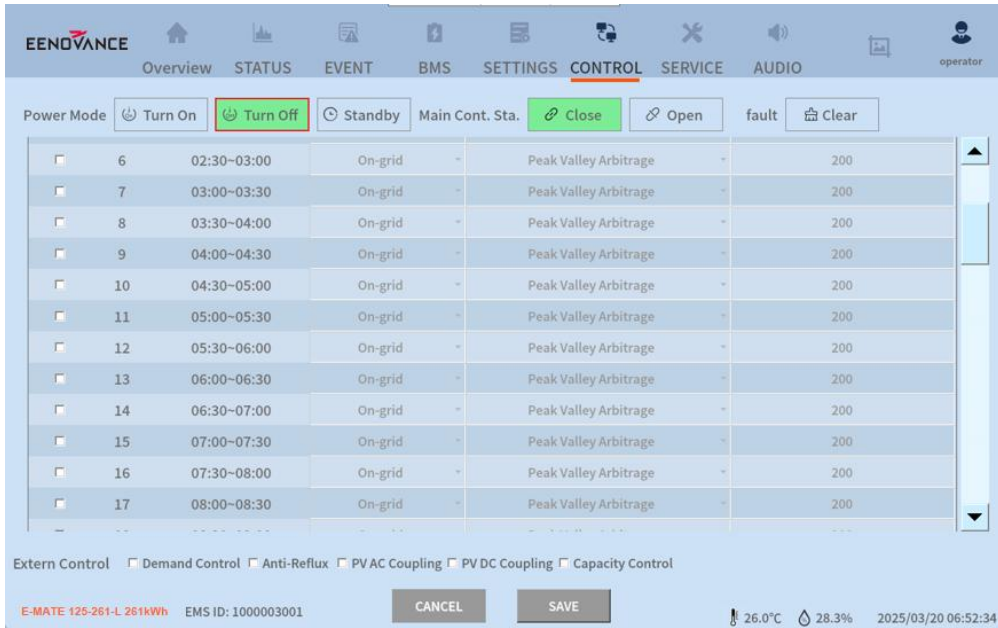

Step 2: If you need to power off completely, on the "Control Strategy" page, click the "Open" button to disconnect the battery contactor.

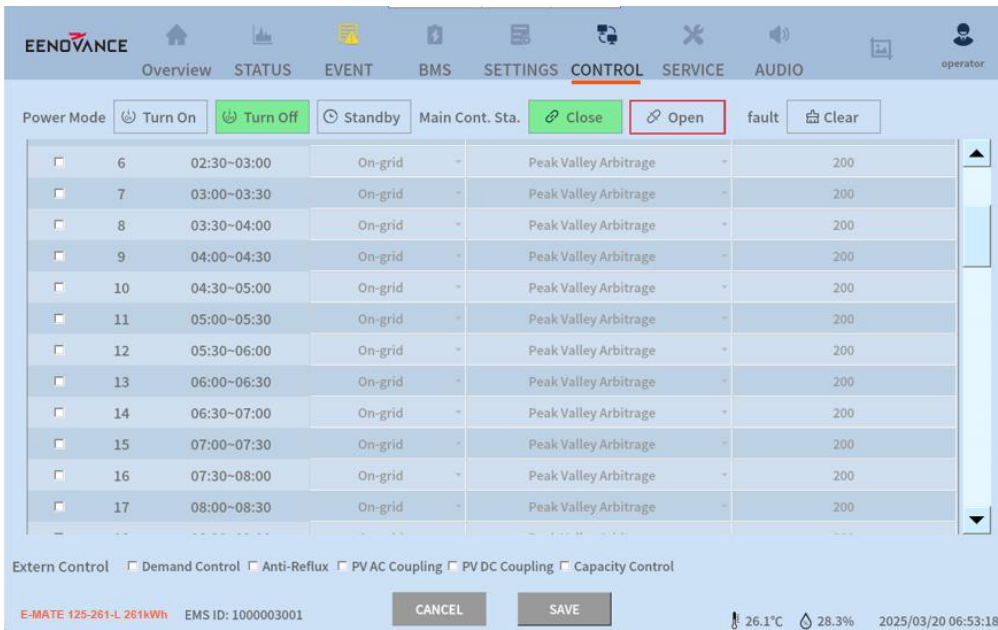

5.3 Emergency Shutdown Procedure

 **DANGER**

- In case of emergency, tap the emergency stop button on the cabinet door and the system will stop running.
- Fire Incident: Contact local professional firefighters.
- System Failure: Contact local aftermarket operator.

6 Battery System Maintenance Instructions

6.1 System Usage Requirements

6.1.1 Precautions Before Maintenance

 **WARNING**

- The customer shall be responsible for any equipment and economic losses and all liabilities caused by off-grid application.
- Violent disassembly and maintenance are prohibited and EENOVANCE will not be held liable for any violation of maintenance regulations.

 **WARNING**

- To avoid electric shock, do not perform any other maintenance operations beyond this manual..
- If necessary, contact EENOVANCE customer service for maintenance.



- Maintenance requires licensed professional maintenance personnel, non-professional maintenance personnel are prohibited to operate.
- If necessary, maintenance intervals can be shortened depending on site conditions

6.1.2 Maintenance (Every two years)

Item	Check method
System status and cleanliness	<ul style="list-style-type: none"> • Check equipment inside the outdoor cabinet for any damage or deformation. • Check for any abnormal noises during the operation of the internal equipment. • Check whether the temperatures inside the outdoor cabinet and on its exterior are excessively high. • Check whether the humidity inside the outdoor cabinet is within the normal range. • Check for any signs of oxidation or rust inside the outdoor cabinet.

6.1.3 Long Without System Usage Requirements

Check the remaining charge and health of the battery.
 Ensure that the battery is stored under suitable temperature and humidity conditions to prevent degradation or damage to the battery.

Check whether the battery management system (BMS) is working properly and ensure that the safety protection functions of the battery system are effective, including overcharging, over-discharging, short-circuit and thermal runaway protection.

Before being put back into service, the energy storage system should be subjected to a comprehensive system test, including battery performance, electrical connections and protective features.

Perform cleaning and maintenance of the system, e.g., cleaning battery contacts, checking the cooling system, etc.

6.1.4 Maintenance (Once a year)

Item	Check method
System status and cleanliness	<ul style="list-style-type: none"> • Check the interior of the outdoor cabinet for foreign objects, dust and grime. Remove interior dust if necessary. • Check the air inlet and outlet of the outdoor cabinet for blockages. • Check for any screw detachment inside the outdoor cabinet. • Check for any water ingress within the outdoor cabinet.
Appearance	<ul style="list-style-type: none"> • Check the enclosure of the outdoor cabinet for damage, paint loss, oxidation, etc. • Check the cabinet door locks, etc. for smooth operation. If necessary, apply appropriate lubricants to door locks, hinges, etc. • Check whether sealing strips, etc. are securely attached. • Properly maintained sealing strips are essential for preventing water ingress into the product. Inspect them carefully, and replace immediately if any sealing strips are found damaged. • Check machine warning signs and other device signs. if any signs are blurred or damaged, replace them promptly.
Cable connections	<ul style="list-style-type: none"> • Check whether all incoming and outgoing cable holes of the outdoor cabinet are well sealed. • Check cable connections for looseness. Retighten any loose cables according to the specified torque. • Check cables for any damage, particularly for cuts on the surface in contact with metal. • Check the insulating cable ties of cable connection terminals for detachment.
Grounding and equipotential connections	<ul style="list-style-type: none"> • Check whether grounding connections are correct. The grounding resistance should not be greater than 4Ω. • Check whether equipotential connections inside the energy storage system are correct. • Check whether the cable shielding layers are in good contact with insulation sleeves, and whether the grounding copper bars are reliably secured.
Fire protection system	<ul style="list-style-type: none"> • Check smoke conditions inside the battery container. • Check the external condition of the equipment for any damages or compressions from nearby equipment. • Check whether the equipment status indicator lights are normal. • Visually inspect the input/output modules. Check the external condition of the equipment for any damages or compressions from nearby equipment. Check whether the equipment status

indicator lights are normal.

6.2 Battery Maintenance

6.2.1 Maintenance Overview

 **WARNING**

Do not leave the product in a low voltage or low SOC condition for a long period of time. Loss of capacity due to the following conditions is not covered by the warranty.

- Battery discharge cell voltage is below 2.7V for 120 consecutive hours.
- Any cell cluster SOC is 0% for 80 consecutive hours.
- Single battery discharge cell voltage $\leq 2.2V$.

- Read the user manual or instruction manual before maintenance.
- Ensure that the battery system is shut down during maintenance.
- Please check and confirm the positive (+) and negative (-) poles before assembly.
- Check insulation before assembly to prevent short circuits.
- It must be stored according to the battery storage environment requirements.
- Maintain the removed batteries and prohibit sunlight and rain.
- Charging and discharging should be carried out in strict accordance with the requirements of this manual.
 - When the battery reaches the specified end-of-life conditions, it should be discontinued in time.

6.2.2 Battery Storage

 **NOTICE**

- If the system is stored for a long period of time (six months or more) without operation, the system needs to do at least 1 full charge in order to activate the battery before the system is used for the first time.
- Battery storage requires proper storage at the appropriate temperature and humidity, otherwise it will reduce the battery's service life.
- It is recommended to adjust the power of product storage to 30% ~ 50%.

Product storage must be kept away from fire and heat sources. When continuous static storage is required for more than 2 months, maintenance should be performed every two months.

6.3 Alarm Reference & Troubleshooting

6.3.1 Liquid Cooler Alarm Troubleshooting

Table 6-1 Liquid Cooler Alarm Troubleshooting

Alarm ID	Alarm message	Alarm level	Possible causes	Troubleshooting
----------	---------------	-------------	-----------------	-----------------

1	Outlet water high temperature alarm	Medium	<ol style="list-style-type: none"> 1. Outlet water temperature probe failure. 2. The compressor, electronic expansion valve, internal circulation water pump or external fan are operating abnormally. 3. The load of the equipment to be cooled exceeds the design cooling capacity of the chiller. 4. Cooling medium circulation system leaks. 	<ol style="list-style-type: none"> 1. Replace the outlet water temperature probe. 2. Check the compressor, electronic expansion valve, internal circulation water pump and external fan. 3. Check the load on the equipment to be cooled. 4. Check the leak and add cooling medium after repair.
2	Outlet water low temperature alarm	Medium	<ol style="list-style-type: none"> 1. Outlet water temperature probe failure. 2. The electric heating pipe or the internal circulation water pump is faulty. 3. The heat leakage of the equipment to be cooled exceeds the design heating capacity of the chiller. 	<ol style="list-style-type: none"> 1. Replace the outlet water temperature probe. 2. Check the electric heating pipe and internal circulation water pump. 3. Check the heat leakage of the equipment to be cooled.
3	Outlet water temperature sensor fault	Medium	<ol style="list-style-type: none"> 1. The temperature sensor's electrical control wiring is loose and the cable is damaged. 2. The temperature sensor is damaged. 	<ol style="list-style-type: none"> 1. Tighten the electrical control wiring or replace the cables. 2. Replace the temperature sensor.
4	Reflux water temperature sensor fault	Medium	<ol style="list-style-type: none"> 1. The temperature sensor's electrical control wiring is loose and the cable is damaged. 2. The temperature sensor is damaged. 	<ol style="list-style-type: none"> 1. Tighten the electrical control wiring or replace the cables. 2. Replace the temperature sensor.

5	Outlet water and Reflux water Low pressure difference	Medium	<ol style="list-style-type: none"> 1. The electrical control wiring of the water pump is loose or the cable is damaged. 2. The cooling medium circulating in the chiller is mixed with air, or there is no cooling medium, causing the water pump to run idle. 	<ol style="list-style-type: none"> 1. Tighten the electric control wiring or replace the cable. 2. Check the cooling medium in the internal circulation.
6	Abnormal communication of compressor drive	Medium	<ol style="list-style-type: none"> 1. The upper computer works abnormally. 2. The inverter communication wiring is loose or the cable is damaged. 	<ol style="list-style-type: none"> 1. Check the connection cable of the host computer. 2. Tighten the communication cables or replace them.
7	System high pressure alarm lock	Medium	<ol style="list-style-type: none"> 1. Outdoor temperature is too high. 2. The high-voltage switch wiring is loose or the cable is damaged. 3. The condenser is seriously dirty and clogged. 4. There is debris blocking the return air outlet on the outdoor side of the chiller. 5. The external circulation fan is powered off or malfunctioning. 	<ol style="list-style-type: none"> 1. Check the outdoor temperature. 2. Tighten the electric control wiring or replace the cable. 3. Clean the condenser. 4. Clean the dirt and obstruction in front of the return air outlet on the indoor side of the unit. 5. If the cause is not a power outage, repair or replace the external circulation fan.
8	System low pressure alarm lock	Medium	<ol style="list-style-type: none"> 1. Refrigerant leak has occurred. 2. Electronic expansion valve working abnormally. 	<ol style="list-style-type: none"> 1. Check the leak point and add refrigerant after repair. 2. Replacement of electronic expansion valve.

9	Exhaust temperature high alarm lock	Medium	<ol style="list-style-type: none"> 1. Outdoor temperature is too high. 2. The condenser is seriously dirty and clogged. 3. There is debris blocking the return air outlet on the outdoor side of the chiller. 4. The external circulation fan is powered off or malfunctioning. 	<ol style="list-style-type: none"> 1. Check the outdoor temperature. 2. Clean the condenser. 3. Clean the dirt and obstruction in front of the return air outlet on the indoor side of the unit. 4. If the cause is not a power outage, repair or replace the external circulation fan.
10	compressor over current alarm	Medium	<ol style="list-style-type: none"> 1. The inverter output circuit is grounded or short-circuited. 2. Low voltage. 3. The inverter is too small. 4. Motor short circuit to ground. 5. Acceleration time is too short, resulting in acceleration overcurrent. 6. Manual torque boost or inappropriate V/F curve causes acceleration overcurrent. 7. Starting a rotating motor causes an acceleration overcurrent. 8. Sudden load during acceleration/deceleration/operation causes overcurrent during acceleration/deceleration/constant speed. 9. The deceleration time is too short, resulting in deceleration overcurrent. 	<ol style="list-style-type: none"> 1. Troubleshooting output circuit failure. 2. Adjust the voltage to the normal range. 3. Replace the inverter with a larger power level. 4. Replace cables or motors. 5. Increase the acceleration time. 6. Adjust the manual lifting torque or V / F curve. 7. Wait for the motor to stop before starting. 8. Cancel sudden load. 9. Increase the deceleration time.
11	compressor over temperature alarm	Medium	<ol style="list-style-type: none"> 1. The cooling air duct of the compressor inverter is blocked. 2. Ambient temperature is too high. 3. Fan failure. 4. Thermistor damage. 5. Inverter module is damaged. 	<ol style="list-style-type: none"> 1. Clean the cooling air duct of the compressor inverter. 2. Reduce ambient temperature. 3. Replace the inverter.

12	compressor over voltage alarm	Medium	<ol style="list-style-type: none"> 1. The input voltage is high. 2. Too short acceleration time leads to acceleration overvoltage. 3. Too short deceleration time leads to deceleration overvoltage. 	<ol style="list-style-type: none"> 1. Adjust the voltage to the normal range. 2. Increase the acceleration time. 3. Increase the deceleration time.
13	compressor under voltage alarm lock	Medium	<ol style="list-style-type: none"> 1. Instantaneous power outage. 2. The voltage at the inverter input terminal is not within the range required by the specification. 3. The rectifier bridge and buffer resistor are abnormal. 4. The driver board is abnormal. 	<ol style="list-style-type: none"> 1. The alarm is automatically cleared after the fault is restored. 2. Adjust the voltage to the normal range. 3. Replace the inverter.
14	compressor phase loss alarm lock	Medium	<ol style="list-style-type: none"> 1. Abnormal lead from inverter to motor. 2. The three-phase output of the inverter is unbalanced when the motor is running. 3. The driver board is abnormal. 	<ol style="list-style-type: none"> 1. Troubleshoot lead connection problems. 2. Replace the motor. 3. Replace the inverter.
15	compressor other alarm lock	Medium	<ol style="list-style-type: none"> 1. The electrical control wiring of the compressor inverter is loose, or the cable is damaged. 2. The compressor inverter is damaged. 3. The inverter is too small. 	<ol style="list-style-type: none"> 1. Tighten the electrical control wiring or replace the cables. 2. Replace the compressor inverter. 3. Choose a frequency converter with a higher power rating.
18	Water replenishment alarm	Medium	The chiller is low on coolant.	Use the refill pump to replenish the coolant.
20	Outlet water over pressure alarm	Medium	<ol style="list-style-type: none"> 1. There is a blockage in the water system. 2. Excessive cooling medium. 	<ol style="list-style-type: none"> 1. Check the water system. 2. Discharge part of the cooling medium pressure relief.

21	Suction temperature sense fault	Medium	<ol style="list-style-type: none"> 1. The temperature sensor's electrical wiring is loose and the cable is damaged. 2. The temperature sensor is damaged. 	<ol style="list-style-type: none"> 1. Tighten the electrical control wiring or replace the cables. 2. Replace the temperature sensor.
22	Low pressure fault	Medium	<ol style="list-style-type: none"> 1. The electrical wiring of the low pressure sensor is loose or the cable is damaged. 2. The low pressure sensor is damaged. 	<ol style="list-style-type: none"> 1. Tighten the electrical control wiring or replace the cables. 2. Replace the low pressure sensor.

6.3.2 EMS Alarm Troubleshooting

Table 6-2 PCS Alarm Troubleshooting

Alarm ID	Alarm message	Alarm level	Troubleshooting
-1001	PCS fault	High	Troubleshooting PCS.
-1002	PCS communication fault	High	Check whether the communication line between EMS and PCS is abnormal.
-1003	BMS fault	High	Troubleshooting BMS.
-1004	BMS communication fault	High	Check whether the communication line between EMS and BMS is abnormal.
-1005	Fire fault	High	Troubleshoot fire-related faults.
-1006	Fire communication fault	High	Check whether the communication line between EMS and IO is abnormal.
-1007	EPO	High	Confirm that the EPO has been reset and click Clear Fault.
-1008	Battery low	High	No need to deal with it.
-2001	PCS alarm	Medium	Troubleshooting PCS.
-2002	PCS communication failed	Medium	Check whether the communication line between EMS and PCS is abnormal.
-2003	BMS alarm	Medium	Troubleshooting BMS.
-2004	BMS communication failed	Medium	Check whether the communication line between EMS and BMS is abnormal.
-2005	Fire alarm	Medium	Troubleshoot fire-related alarm.
-2008	Battery low	Medium	No need to deal with it.
-2009	Site communication failed	Medium	Check whether the 4G card and 4G suction cup antenna are properly plugged in. Then restart the system.
-2011	Liquid cooler communication failed	Medium	Check whether the communication line between EMS and Liquid cooler is abnormal.

6.3.3 BMS Alarm Troubleshooting

Table 6-3 BMS alarm troubleshooting

Alarm ID	Alarm message	Alarm level	Troubleshooting
1	Rack terminal over-voltage Level-1 Alarm	Low	No need to deal with it.
2	Rack terminal over-voltage Level-2 Alarm	Medium	No need to deal with it.
3	Rack terminal over-voltage Level-3 Alarm	High	<ul style="list-style-type: none"> • Confirm the fault condition on-site and close the high-voltage box circuit breaker again. • Clear the fault and power up the system again. • If the issue is not resolved, please contact the supplier for further assistance.
4	Rack terminal under-voltage Level-1 Alarm	Low	No need to deal with it.
5	Rack terminal under-voltage Level-2 Alarm	Medium	No need to deal with it.
6	Rack terminal under-voltage Level-3 Alarm	High	<ul style="list-style-type: none"> • Confirm the fault condition on-site and close the high-voltage box circuit breaker again. • Clear the fault and power up the system again. • If the issue is not resolved, please contact the supplier for further assistance.
7	Rack terminal discharge over-current Level-1 Alarm	Low	No need to deal with it.
8	Rack terminal discharge over-current Level-2 Alarm	Medium	No need to deal with it.
9	Rack terminal discharge over-current Level-3 Alarm	High	<ul style="list-style-type: none"> • Confirm the fault condition on-site and close the high-voltage box circuit breaker again. • Clear the fault and power up the system again. • If the issue is not resolved, please contact the supplier for further assistance.

10	Rack terminal charge over-current Level-1 Alarm	Low	No need to deal with it.
11	Rack terminal charge over-current Level-2 Alarm	Medium	No need to deal with it.
12	Rack terminal charge over-current Level-3 Alarm	High	<ul style="list-style-type: none"> • Confirm the fault condition on-site and close the high-voltage box circuit breaker again. • Clear the fault and power up the system again. • If the issue is not resolved, please contact the supplier for further assistance.
13	Rack terminal isolation Level-1 Alarm	Low	No need to deal with it.
14	Rack terminal isolation Level-2 Alarm	Medium	No need to deal with it.
15	Rack terminal isolation Level-3 Alarm	High	<ul style="list-style-type: none"> • Confirm the fault condition on-site and close the high-voltage box circuit breaker again. • Clear the fault and power up the system again. • If the issue is not resolved, please contact the supplier for further assistance.
16	Cell charge over-temperature Level-1 Alarm	Low	No need to deal with it.
17	Cell charge over-temperature Level-2 Alarm	Medium	No need to deal with it.
18	Cell charge over-temperature Level-3 Alarm	High	<ul style="list-style-type: none"> • Confirm the fault condition on-site and close the high-voltage box circuit breaker again. • Clear the fault and power up the system again. • If the issue is not resolved, please contact the supplier for further assistance.
19	Cell charge under-temperature Level-1 Alarm	Low	No need to deal with it.
20	Cell charge under-temperature Level-2 Alarm	Medium	No need to deal with it.

21	Cell charge under-temperature Level-3 Alarm	High	<ul style="list-style-type: none"> • Confirm the fault condition on-site and close the high-voltage box circuit breaker again. • Clear the fault and power up the system again. • If the issue is not resolved, please contact the supplier for further assistance.
22	Cell over-voltage Level-1 Alarm	Low	No need to deal with it.
23	Cell over-voltage Level-2 Alarm	Medium	No need to deal with it.
24	Cell over-voltage Level-3 Alarm	High	<ul style="list-style-type: none"> • Confirm the fault condition on-site and close the high-voltage box circuit breaker again. • Clear the fault and power up the system again. • If the issue is not resolved, please contact the supplier for further assistance.
25	Cell under-voltage Level-1 Alarm	Low	No need to deal with it.
26	Cell under-voltage Level-2 Alarm	Medium	No need to deal with it.
27	Cell under-voltage Level-3 Alarm	High	<ul style="list-style-type: none"> • Confirm the fault condition on-site and close the high-voltage box circuit breaker again. • Clear the fault and power up the system again. • If the issue is not resolved, please contact the supplier for further assistance.
28	Cell high voltage-difference Level-1 Alarm	Low	No need to deal with it.
29	Cell high voltage-difference Level-2 Alarm	Medium	No need to deal with it.
30	Cell high voltage-difference Level-3 Alarm	High	<ul style="list-style-type: none"> • Confirm the fault condition on-site and close the high-voltage box circuit breaker again. • Clear the fault and power up the system again. • If the issue is not resolved, please contact the supplier for further assistance.
31	Cell high temperature-difference Level-1 Alarm	Low	No need to deal with it.
32	Cell high temperature-difference Level-2 Alarm	Medium	No need to deal with it.
33	Cell high temperature-difference Level-3 Alarm	High	<ul style="list-style-type: none"> • Confirm the fault condition on-site and close the high-voltage box circuit breaker again. • Clear the fault and power up the system again.

	Alarm		<ul style="list-style-type: none"> If the issue is not resolved, please contact the supplier for further assistance.
34	Low SOC Level-1 Alarm	Low	No need to deal with it.
35	Low SOC Level-2 Alarm	Medium	No need to deal with it.
36	Low SOC Level-3 Alarm	High	No need to deal with it.
54	Internal CAN communication disconnect	High	<ul style="list-style-type: none"> Confirm the fault condition on-site and close the high-voltage box circuit breaker again. Clear the fault and power up the system again. If the issue is not resolved, please contact the supplier for further assistance.
55	Cell voltage DAQ abnormal	High	<ul style="list-style-type: none"> Confirm the fault condition on-site and close the high-voltage box circuit breaker again. Clear the fault and power up the system again. If the issue is not resolved, please contact the supplier for further assistance.
56	Cell temperature DAQ abnormal	High	<ul style="list-style-type: none"> Confirm the fault condition on-site and close the high-voltage box circuit breaker again. Clear the fault and power up the system again. If the issue is not resolved, please contact the supplier for further assistance.
64	CAN Hall sensor fault	High	<ul style="list-style-type: none"> Confirm the fault condition on-site and close the high-voltage box circuit breaker again. Clear the fault and power up the system again. If the issue is not resolved, please contact the supplier for further assistance.
65	CAN Hall sensor communication fault	High	<ul style="list-style-type: none"> Confirm the fault condition on-site and close the high-voltage box circuit breaker again. Clear the fault and power up the system again. If the issue is not resolved, please contact the supplier for further assistance.
71	Cell discharge over-temperature Level-1 Alarm	Low	No need to deal with it.
72	Cell discharge over-temperature Level-2 Alarm	Medium	No need to deal with it.
73	Cell discharge over-temperature Level-3 Alarm	High	<ul style="list-style-type: none"> Confirm the fault condition on-site and close the high-voltage box circuit breaker again. Clear the fault and power up the system again. If the issue is not resolved, please contact the supplier for further assistance.

74	Cell discharge under-temperature Level-1 Alarm	Low	No need to deal with it.
75	Cell discharge under-temperature Level-2 Alarm	Medium	No need to deal with it.
76	Cell discharge under-temperature Level-3 Alarm	High	<ul style="list-style-type: none"> • Confirm the fault condition on-site and close the high-voltage box circuit breaker again. • Clear the fault and power up the system again. • If the issue is not resolved, please contact the supplier for further assistance.
77	High SOC Level-1 Alarm	Low	No need to deal with it.
78	High SOC Level-2 Alarm	Medium	No need to deal with it.
79	High SOC Level-3 Alarm	High	No need to deal with it.

6.3.4 PCS Alarm Troubleshooting

Table 6-4 PCS alarm troubleshooting

Alarm ID	Alarm message	Alarm level	Troubleshooting
1	AC undervoltage	High	1. Check AC voltage and frequency.
2	AC overvoltage	High	2. If the AC voltage and frequency are outside the allowable range, please contact the local power company for a solution;
3	AC overfrequency	High	3. If the AC voltage and frequency are within the allowable range, please contact after-sales personnel.
4	AC underfrequency	High	
5	AC voltage imbalance	High	1. Check AC voltage. 2. If the AC voltage imbalance are outside the allowable range, please contact the local power company for a solution; 3. If the AC voltage imbalance are within the allowable range, please contact after-sales personnel.
6	AC current imbalance	High	please contact after-sales personnel.
9	AC reverse order	High	Check whether the AC phase sequence is correct.
10	AC phase missing	High	Check that the AC power is connected correctly.
11	Abnormal AC voltage	High	1. Check AC voltage and frequency.
12	Frequency anomaly	High	2. If the AC voltage and frequency are outside the allowable range, please contact the local power company for a solution;

			3. If the AC voltage and frequency are within the allowable range, please contact after-sales personnel.
14	AC side short circuit protection	High	Check whether the AC voltage is short-circuited. If not, please contact after-sales personnel.
15	Abnormal AC voltage to ground	High	Please contact after-sales personnel.
22	AC overcurrent	High	Please contact after-sales personnel.
29	Battery undervoltage	High	Check whether the battery is connected correctly and the switch is closed. Check whether the undervoltage protection point setting value is appropriate.
30	Battery overvoltage	High	Check whether the battery voltage exceeds the overvoltage protection point. Check whether the overvoltage protection point setting value is appropriate
31	Battery connected reversely	High	Check that the battery connections are correct.
32	Battery overcurrent	High	1. Check whether the setting value of the charge and discharge current protection point is appropriate. 2. Check whether the working current exceeds the charge and discharge current of the battery when the device is working. 3. If the fault cannot be eliminated, please contact after-sales personnel.
33	Abnormal insulation resistance	High	Check the battery pack for any abnormalities in insulation.
36	DC lightning arrester failure	High	Please contact after-sales personnel.
37	AC lightning arrester failure	High	Please contact after-sales personnel.
95	Q_U parameter setting error	High	Check that the Q_U curve is within the set points and the voltage is set in order from small to large.
96	P_Freq parameter setting error	High	Check if the P_Freq curve is within the set points and the frequencies are set in ascending order.
97	Model capacity setting error/failed	High	Check whether the rated capacity and rated voltage settings match.
98	Frequency response curve setting error	High	Check the frequency response curve to see if the frequency settings are set in order from small to large.
133	Turbine fan failure	High	Please contact after-sales personnel.
134	IGBT fan failure	High	Please contact after-sales personnel.