









PowerCombo-20C2H1000KLS electrical connection instruction

Table of Contents

1. Electrical Connection	1
1.1 Needed tools	1
1.2 Preparing for Connection	2
1.3 Connecting Cables to the Primary Distribution Box	7
1.4 Connecting Cables to the control Box	17
1.5 Synchronous signal wire	20
1.6 Work after connection	23

1. Electrical Connection

1.1 Needed tools

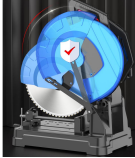
Needed tools		Description
Network Cable Pliers (8P)		Used to tighten the connector of the AC cable
3mm flat-head screwdriver		Tighten the dry contact signal cable
Torque wrench (19mm)		Used to tighten AC cable nuts
Open end wrench (19mm)		Used to fix the connection nut
Hexagon wrench (5mm)		For battery PACK and PCS room ceiling bracket installation
Diagonal cutting pliers		Used to cut protection ring on fire solenoid valve
Electric hand drill		It is used with double head cross head for disassembly and installation of equipment
Double head cross head		It is used with electric hand drill for disassembly and installation of equipment
Multimeter		Used to measure power grid, battery voltage and frequency
Cutting machine		Cut the entry hole baffle

1.2 Preparing for Connection

Cable inlet holes are reserved for system containers. The AC power input hole (aperture size:680x295mm) and AC Auxiliary power,Communication input hole (aperture size: 110 x 260mm), which is located at the bottom of the primary distribution box.

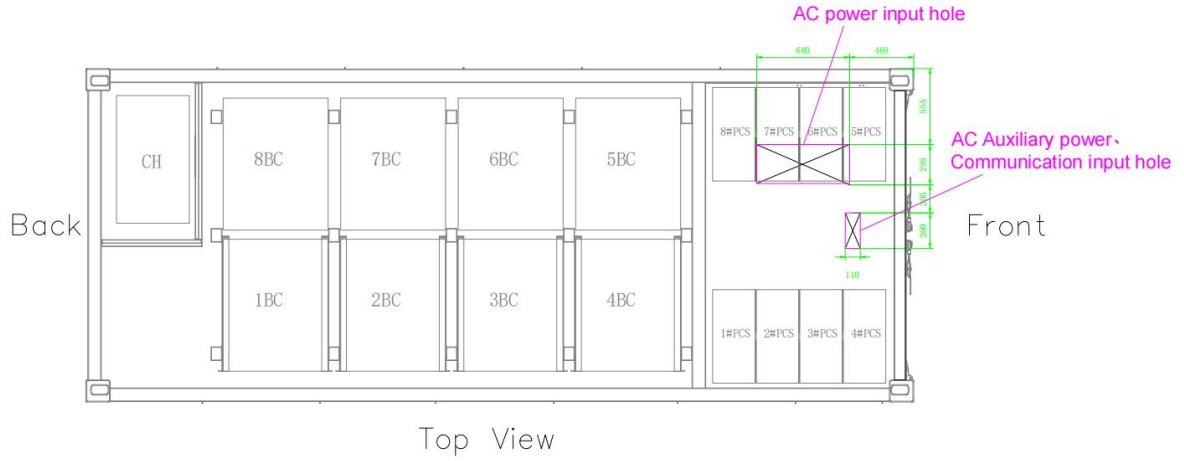

Figure 6-1 Diagram of cable inlet holes at the bottom of a container

Tool name	picture
Electric hand drill	
Double head cross head	

1.2.1 Remove the AC power inlet hole baffle in the primary distribution box.

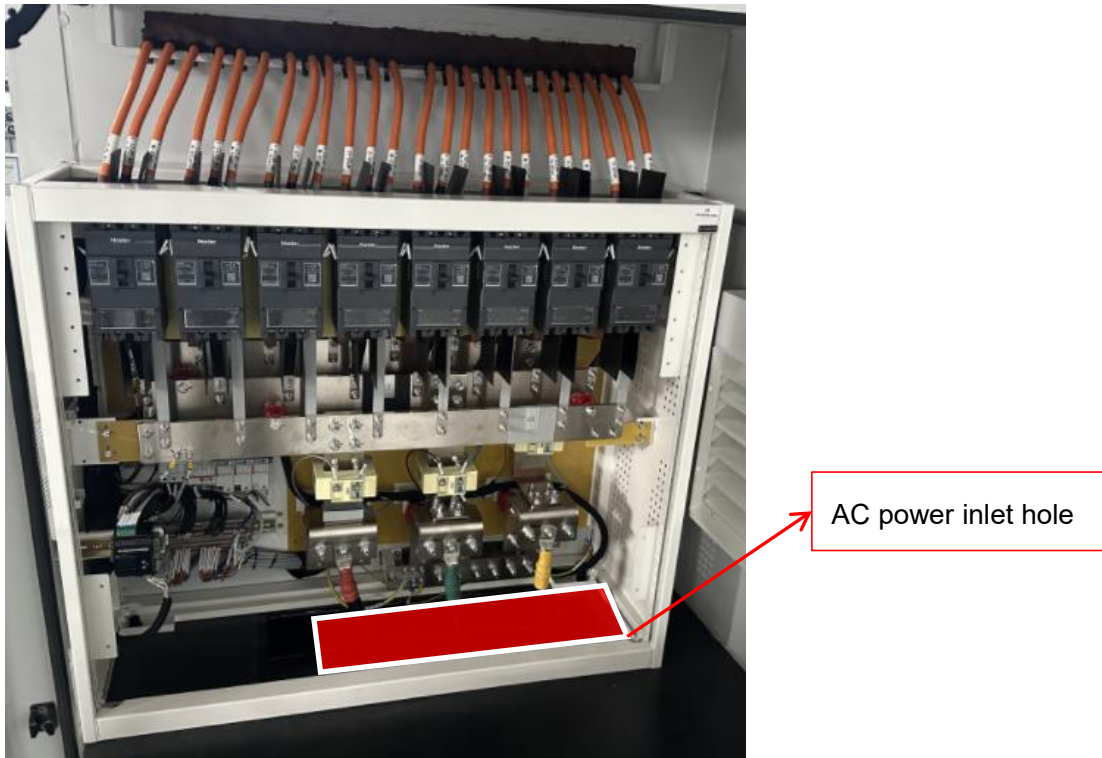

Figure 6-2 The location of AC power inlet hole in primary distribution box(CB)

Step1: Open the door of primary distribution box



Figure 6-3 The door of primary distribution box(Left view from back of the container)



Figure 6-4 The door of primary distribution box opened

Step2: Remove the inlet hole baffle

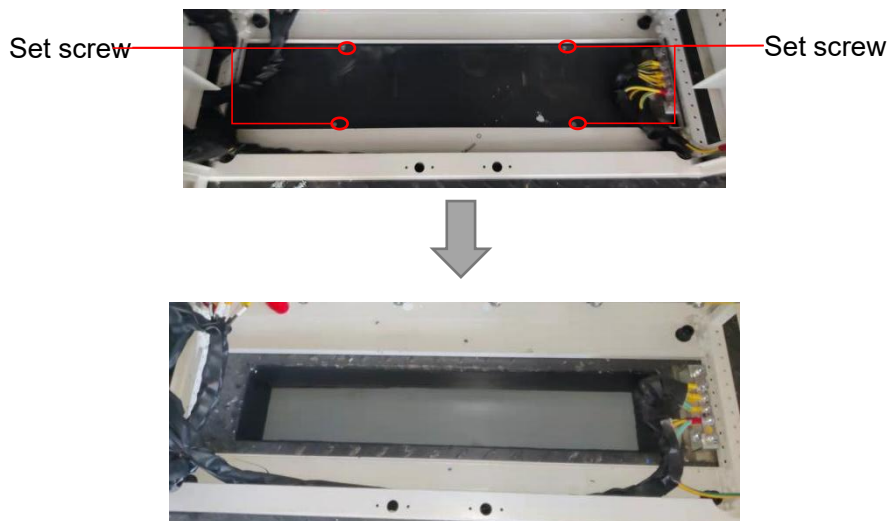

Figure 6-5 The inlet hole baffle is removed

1.2.2 Remove the AC Auxiliary power,Communication input hole.

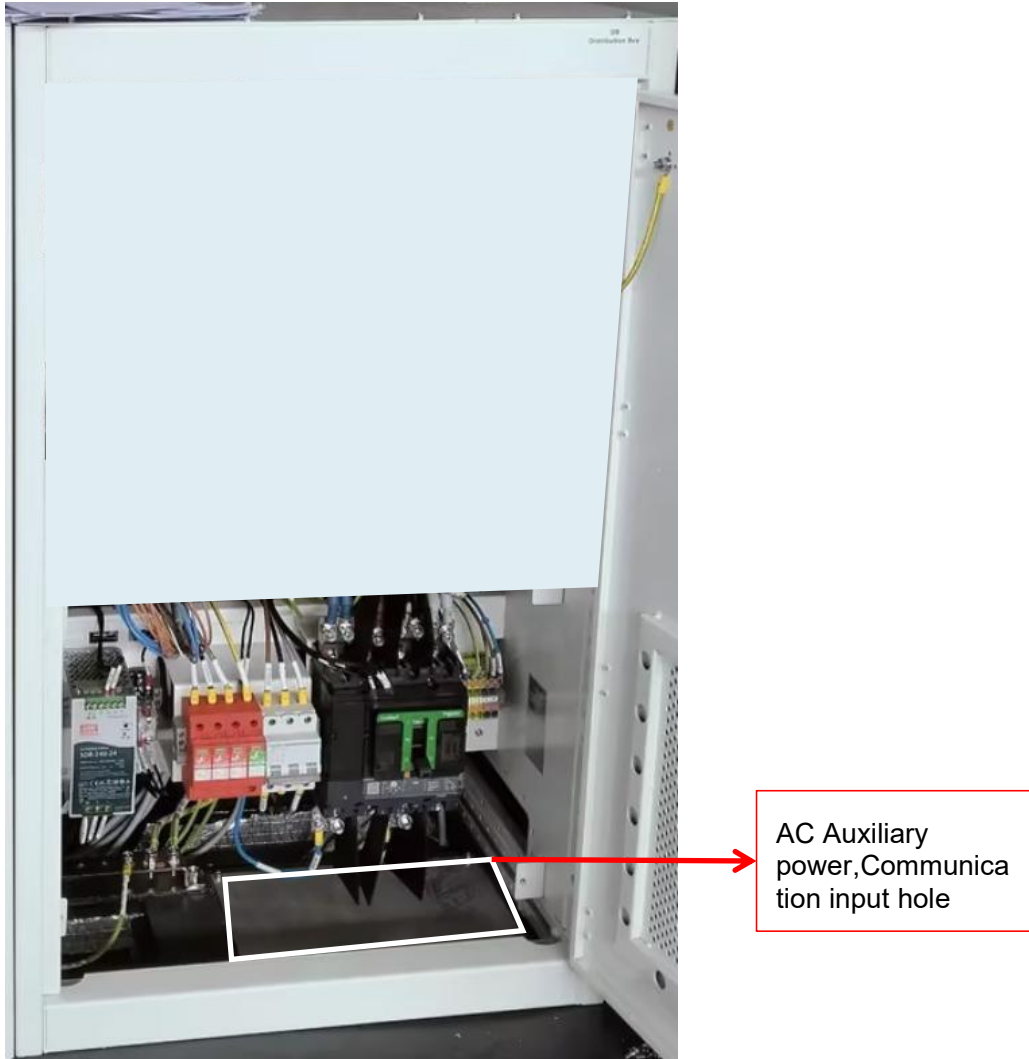
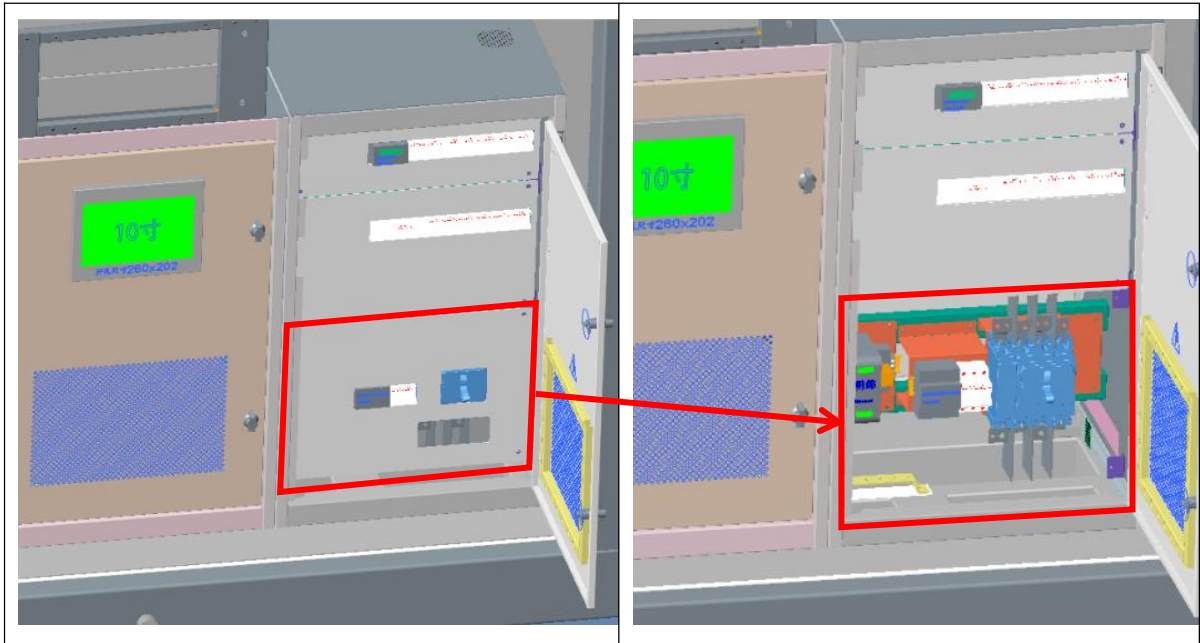

Figure 6-6 The location of AC Auxiliary power,Communication input hole in distribution box(DB)

Step1: Open the door of distribution box(DB),remove the baffle.



Remove the baffle

Step2: Remove the inlet hole baffle

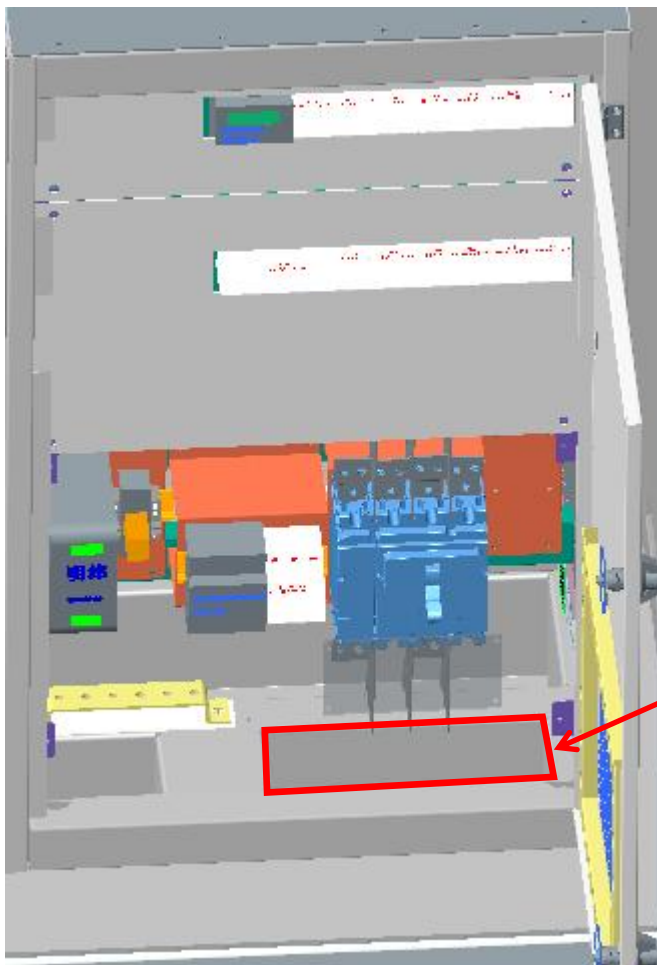

AC Auxiliary
power,Communica
tion input hole

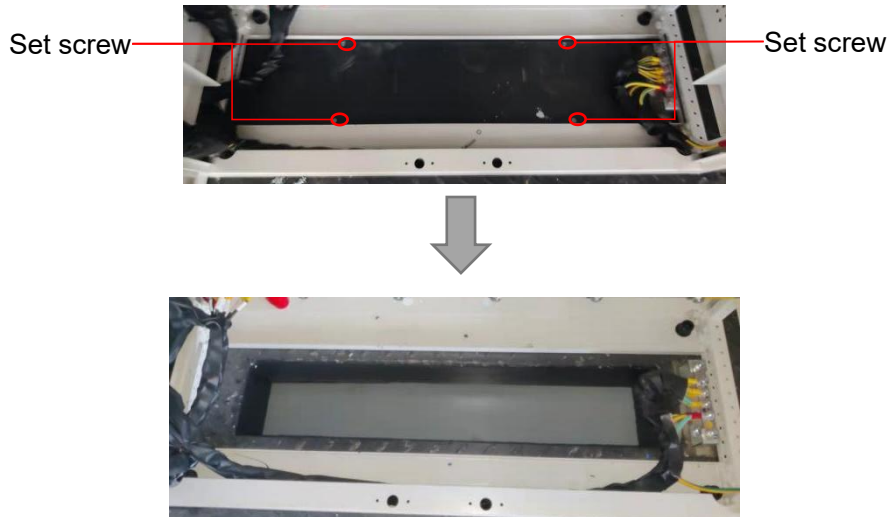

Figure 6-7 The inlet hole baffle is removed

1.3 Connecting Cables to the Primary Distribution Box

1.3.1 Power cable connection

The outgoing terminal of the system is located in the distribution box, and the AC outputs of 8 PCS modules converge on the busbar through the circuit breaker. The outgoing mode of the system is three-phase three wire, as shown in Figure 6-6 system AC outgoing busbar. The internal equipment of the system has been grounded, and the grounding can be repeated if necessary.



WARNING

When the AC cable is connected to the system, please confirm that the PCS AC circuit breakers QF21 ~ QF28 in the distribution box are disconnected.



WARNING

Hazardous Voltage Circuits.



Any contact with the copper bars, contactors, or terminals inside the device or connected with the loop of the utility grid might result in burning or fatal electric shock.

The following operations need to cut off the power supply of PCS to avoid electric shock during operation.



WARNING

To reduce the risk of injury please read this entire manual and pay attention to all safety placards.

WARNING

Arc Flash Hazard

System Voltage	690 Vac
Arc Flash Boundary	0.79 ft
PPE Category	2

Risk of Electric Shock or Other Serious Injury.
Care shall be taken when entering enclosure -
Authorized personnel only.

Attention.

Risque d'éclair d'arc

Tension du système	690 Vac
Limite éclair d'arc	0.79 ft
PPE Catégorie	2

Risque de choc électrique ou d'autres blessures graves.
Des précautions doivent être prises lors de l'entrée
dans l'enceinte-personnel autorisé seulement.

The AC circuit breakers disconnects the Modular Energy Storage Conversion(PCS) from the Grid(QF21~QF28).

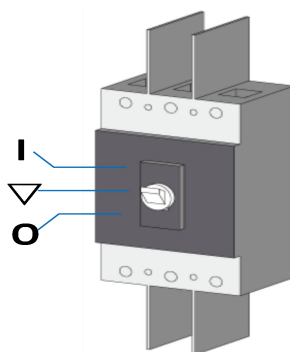

Figure 6-8 Switch positions of the PCS AC circuit breakers

Table 6-1 PCS AC circuit breaker switch position status description

Symbol	Designation	Explanation
I	Switch position In (On)	The AC disconnection unit is closed.
∇	Central switch position	The AC disconnection unit was tripped and is open.
O	Switch position off	The AC disconnection unit is open.



DANGER

Before connecting to the power grid, check the line voltage and voltage phase sequence using the phase sequence table to ensure that the system meets the grid connection conditions



NOTICE

AC outgoing busbars are U phase (brown), V phase (orange), and W phase (yellow) from top to bottom.

1.3.1.1 Primary distribution box power cable connection

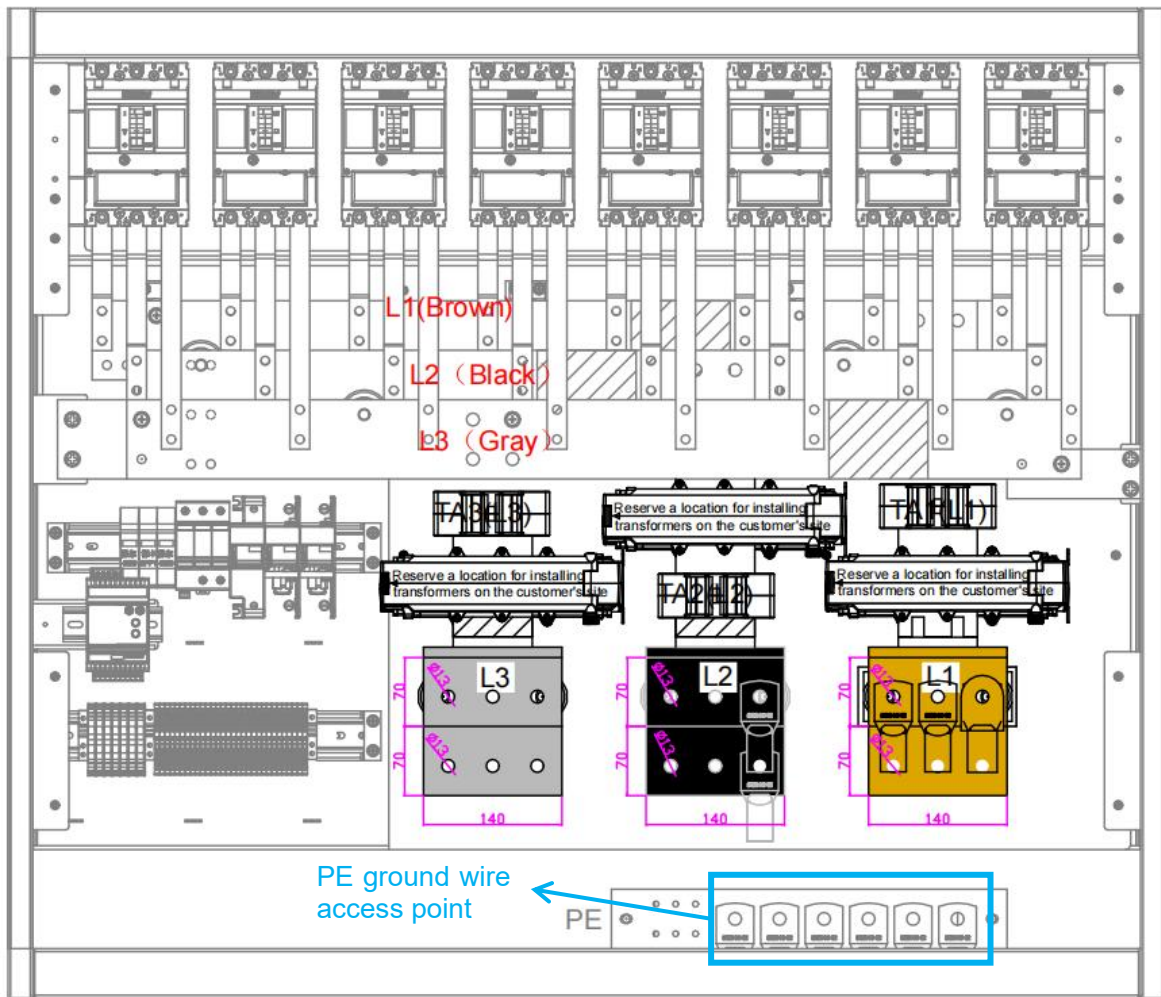

Figure 6-9 Primary distribution box Ac outlet bus size

Tool name	picture
Torque wrench (19mm)	
Open end wrench (19mm)	

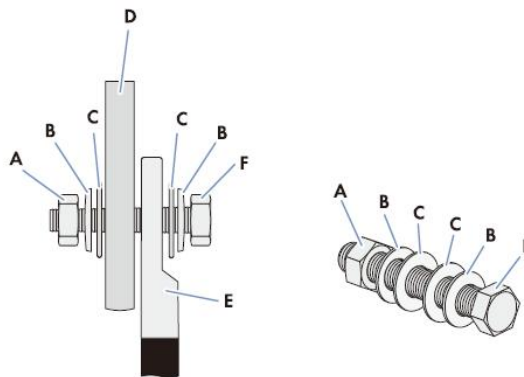

Figure 6-10 Design of the connection with one one-hole terminal lug

Table 6-2 Terminal structure composition

Position	
A	Nut M12
B	Spring washer
C	Fender washer
D	Connection BUS bar
E	Tin-plated one-hole terminal lug
F	Screw M12

The diameter of the busbar cable is 13mm, and 6 AC connection holes are reserved for each phase. For the specifications selection and recommended tightening torque of grid-connected AC cables, see Table 6-3 AC cable specification recommendation.

The PE grounding wire uses two 240mm² cables connect to the two holes on the right side of the grounding bar, as shown in the Figure 6-9.

Table 6-3 AC cable specification recommendation:

Model	Rated AC current	Recommended conductor cross-section	Tightening torque (N.m)	Set screw
20C2H1000KLS	1,443.4A	3 phases + PE: 4* (3*240+1*120) mm ²	40N.m	M12

1.3.1.2 Distribution box power cable connection

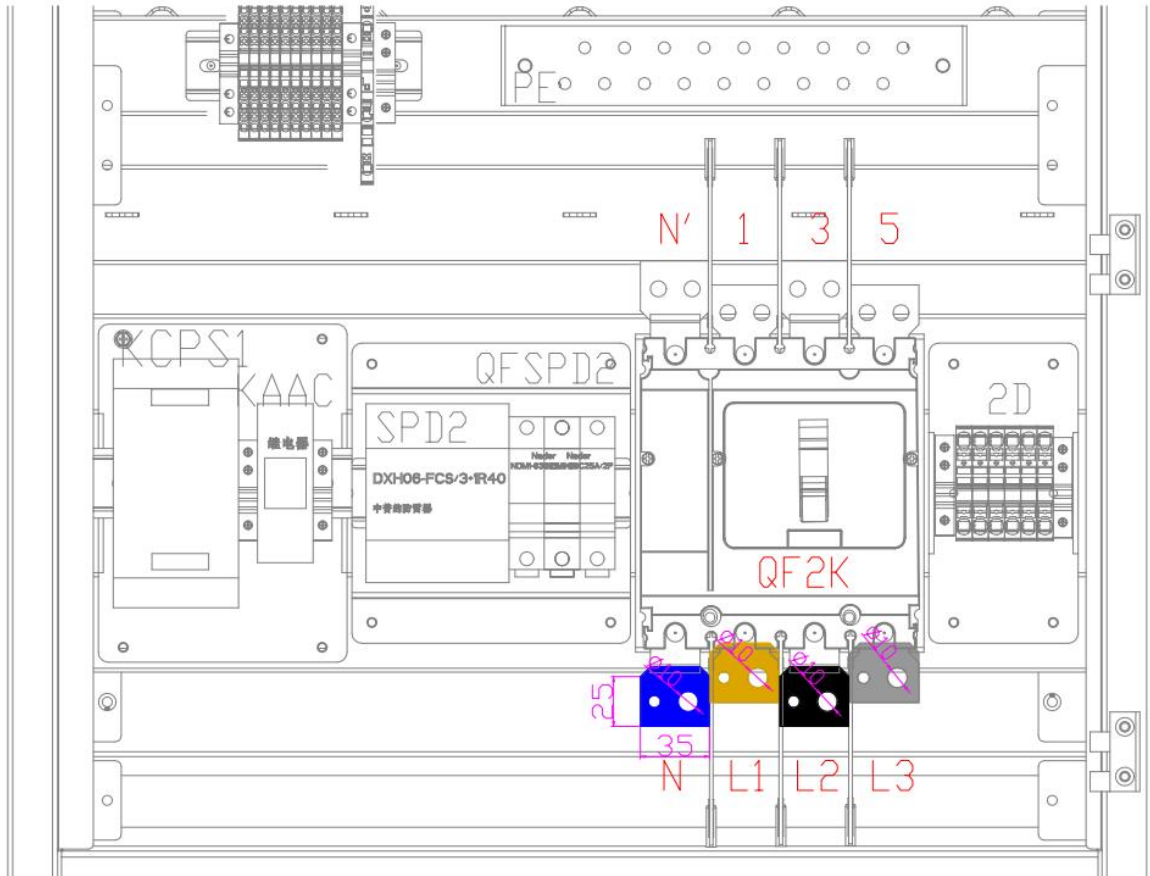

Figure 6-11 Distribution box Ac outlet bus size

Tool name	picture
Torque wrench (14mm)	
Open end wrench (14mm)	

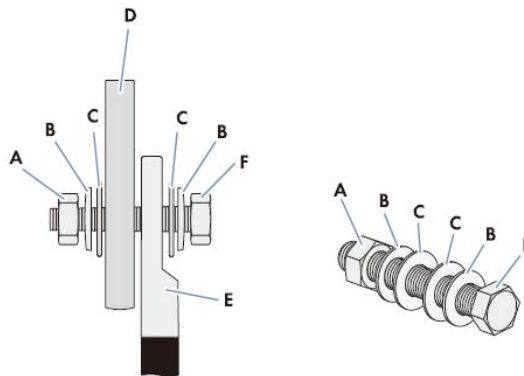

Figure 6-12 Design of the connection with one one-hole terminal lug

Table 6-4 Terminal structure composition

Position	
A	Nut M8
B	Spring washer
C	Fender washer
D	Connection BUS bar
E	Tin-plated one-hole terminal lug
F	Screw M8

The diameter of the busbar cable is 10mm, and 1 AC connection hole are reserved for each phase. For the specifications selection and recommended tightening torque of grid-connected AC cables, see Table 6-5 Auxiliary Power AC cable specification recommendation.

Table 6-5 Auxiliary Power AC cable specification recommendation

Model	Auxiliary Power Maximum AC current	Recommended conductor cross-section	Tightening torque (N.m)	Set screw
20C2H1000KLS	55A	3 phases + N: 4 * 50mm ² copper four-core cable	14 N.m	M8



NOTE

The current carrying capacity of the above cables only supports the connection within 5m. If the length exceeds 5M, the cables with greater current carrying capacity shall be used or the number of cables shall be increased.

For the selection of AC input and output copper core cables of the system, please refer to the cable ampacity recommended in the table above, and select upward according to the installation environment.

OT/DT Terminal requirements



NOTICE

When using copper core cables, please use copper terminals.

When using copper-clad aluminum cables, please use copper terminals.

When using aluminum alloy cables, please use copper aluminum transition terminals, or aluminum terminals with copper aluminum transition gaskets.



NOTICE

It is strictly forbidden to connect the aluminum terminal directly to the terminal strip, otherwise it will cause electrochemical corrosion and affect the reliability of cable connection.

When copper aluminum transition terminal is used, or aluminum terminal is matched with copper aluminum transition gasket, it shall meet the requirements of IEC61238-1.

When using copper aluminum transition gaskets, please pay attention to the front and back sides to ensure that the aluminum surface of the gasket contacts the aluminum terminal and the copper surface contacts the terminal strip.

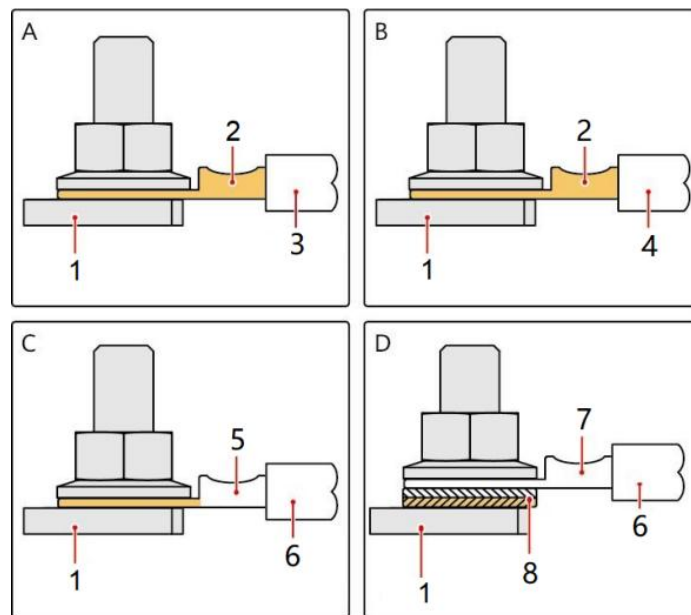

Figure 6-13 OT/DT terminal description

Table 6-6 OT/DT terminal description

Symbol	Explain	Symbol	Explain
1	Terminal strip(copper)	5	Copper aluminum transition terminal block
2	Copper terminal block	6	Aluminum alloy cable
3	Copper cable	7	Aluminum terminal block
4	Copper clad aluminum cable	8	Copper aluminum transition gasket

Crimp OT/DT terminal



NOTICE

Do not scratch the wire core when peeling off the protective layer.

The cavity formed by the conductor crimping piece of OT/DT terminal after crimping shall completely cover the wire core, and the wire core shall be closely combined with OT/DT terminal without looseness.

The crimping gap can be covered with heat shrinkable sleeve or insulating tape. Take the heat shrinkable casing as an example.

When using the hot-air gun, please pay attention to protection to prevent the equipment from being burnt.

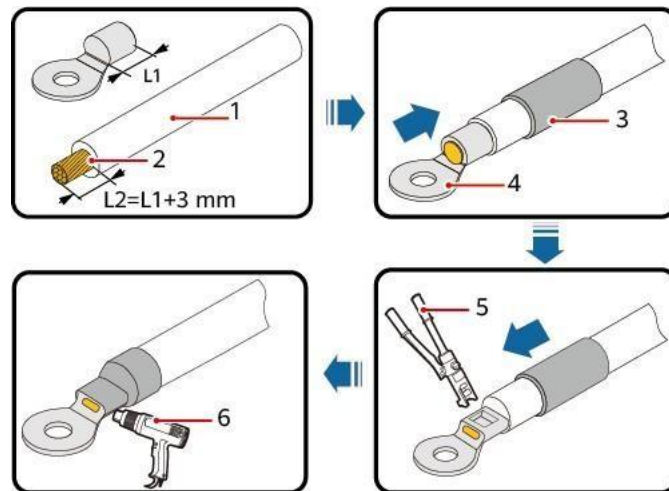

Figure 6-14 Crimping OT terminal steps

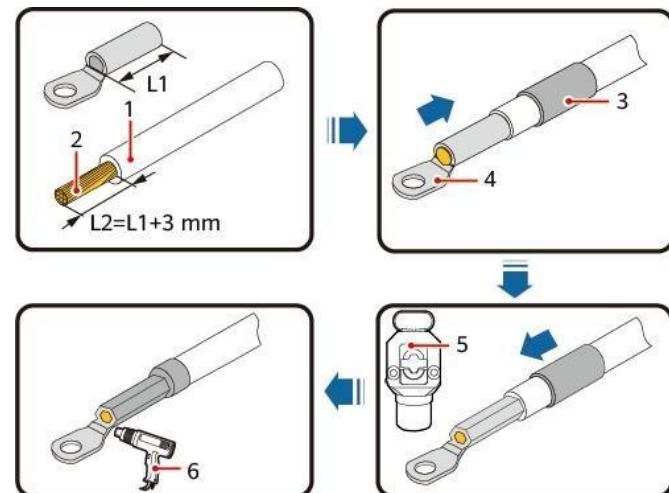

Figure 6-15 Crimping DT terminal steps

Table 6-7 Description of crimping OT/DT terminal equipment

Symbol	Explain	Symbol	Explain
1	Cable	4	OT/DT terminal
2	Wire core	5	hydraulic clamp
3	Heat shrinkable sleeve	6	Hot air gun

1.3.2 Dry Contact Signal Connection

On the 0D terminal block of the control box, a system function signal input / output port is reserved, including analog input signal, 485 communication, passive dry contact output and 24V active dry contact input signal. Users can choose whether to use it according to their needs.

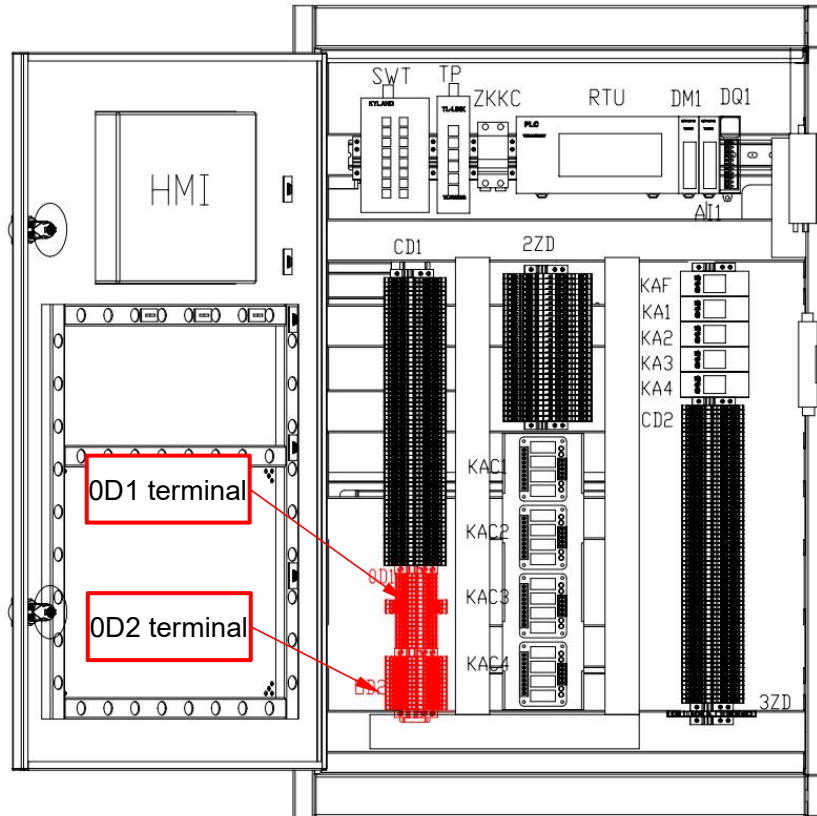



Figure 6-16 0D terminal strip position

Tool name	Picture
3mm flat-head screwdriver	

OD1	Wire Row	Comments
	1	Power transmitter signal 1 (+10V)
	2	Power transmitter signal 1 (-10V)
	3	Power transmitter signal 2 (+10V)
	4	Power transmitter signal 2 (-10V)
	5	Watt-hour meter RS485A
	6	Watt-hour meter RS485B
Communication cable shield	7	○
	8	○
	9	○
Container fire alarm DO	10	
	11	
Trip QF1 switch	12	
	13	
QF1 switch closing signal	14	
	15	
External emergency stop button (NO)	16	
	17	

OD2	Wire Row	Comments
Digital input common terminal	1	○
	2	○
	3	○
	4	○
Three-way valve V2.1 external signal	5	
Three-way valve V2.1 internal signal	6	
Three-way valve V2.2 external signal	7	
Three-way valve V2.2 internal signal	8	
	9	
Allow PMS control signal (DO)	10	
PMS Control Request Signal	11	
Spare	12	
Spare	13	
Spare	14	
	15	
Allow PMS control signal (DO)	16	

Figure 6-17 Reserved function signal terminal

1.4 Connecting Cables to the control Box

1.4.1 Cable Routing Instructions for the Control Box

The distribution box (DB) and control box (GPC) are located below the PCS, the distribution of the distribution room is shown in Figure 6-18 Distribution room layout

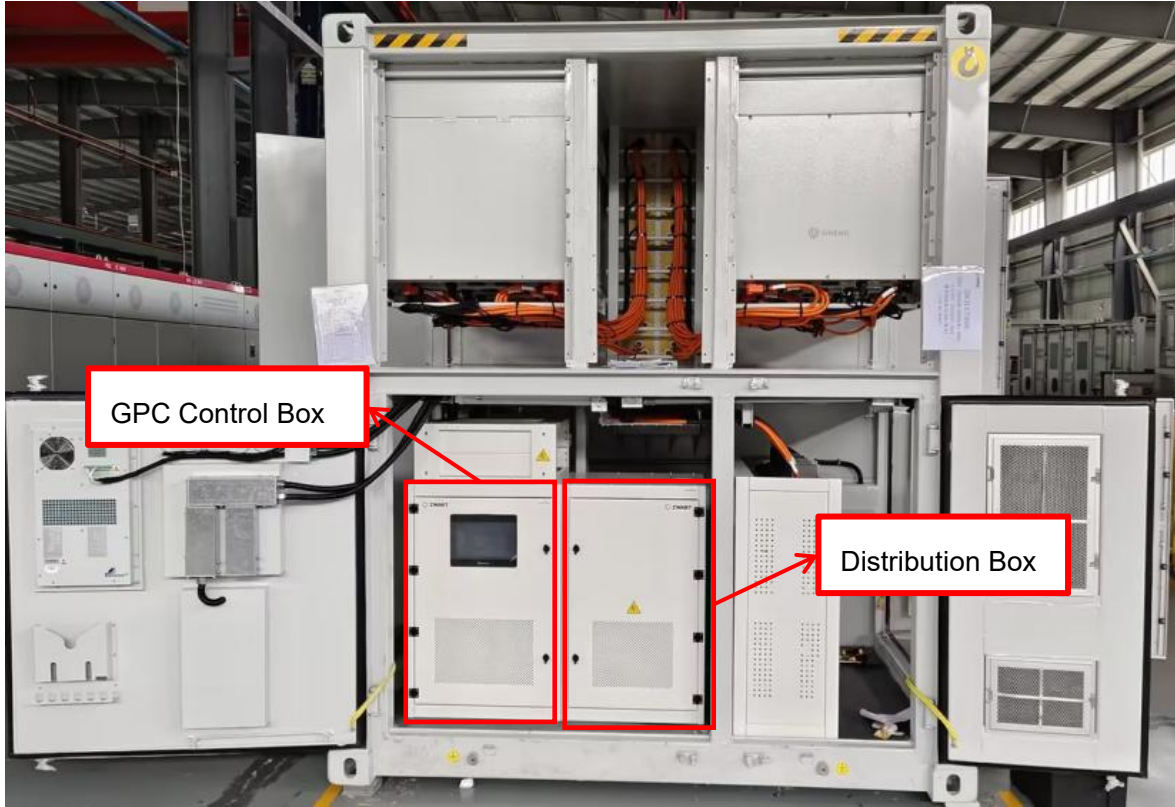

Figure 6-18 Distribution room layout

The path between the network cable and the GPC control box is indicated by the yellow arrow, as shown in Figure 6-19 Wiring path of control box.

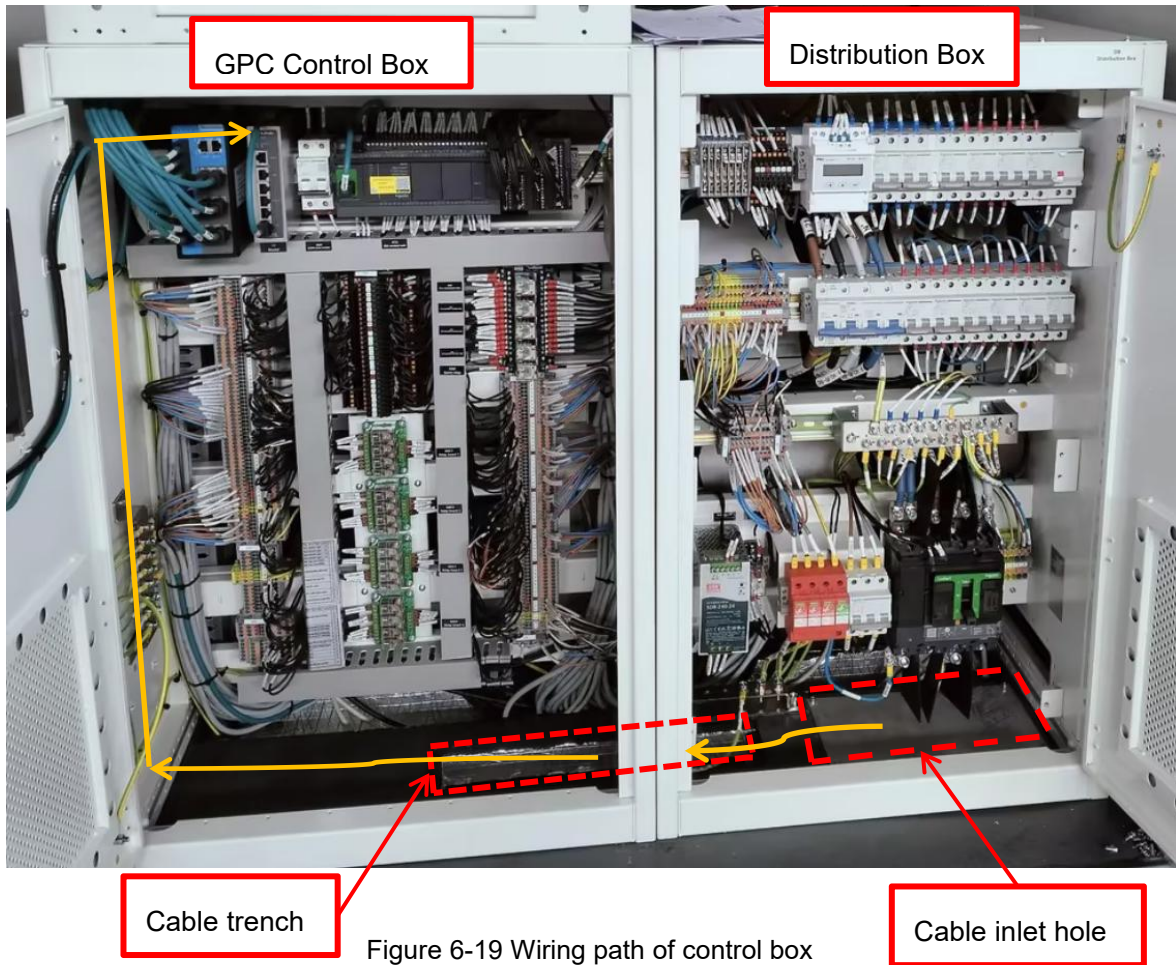

Figure 6-19 Wiring path of control box

1.4.2 EMS communication access

The 20C2H1000KLS provides an RJ45 network port for easy access.

This port is located in the GPC control box, the network cable enters the distribution box through the cable inlet hole on the container, and enters the control box through the cable hole on the top of the distribution box. Figure 6-19 Wiring path of control box shows how to connect cables to the control box.

Connect the network cable to the WAN port of the router (TP) in the GPC controller enclosure.



Figure 6-20 EMS communication access port

RJ45 production sequence description

Tool name	picture
Network Cable Pliers (8P)	

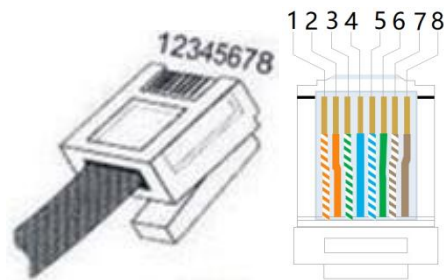

Figure 6-21 RJ45 Port sequence Description

Table 6-8 RJ45 Port sequence definition

Pin	Color	Description
1	Orange and white	Send data
2	Orange	Send data
3	Green and white	Send data
4	Blue	Reserve
5	Blue and white	Reserve
6	Green	Received data
7	Brown	Reserve
8	Brown and white	Reserve

1.5 Synchronous signal wire

If only one system is connected to a copper bar of the transformer, there is no need to install a synchronous signal wire. If two or three systems are connected to the same copper bar of the transformer, synchronous signal wires need to be installed.

Cable requirement: Shielded twisted pair cables (cross-sectional area > 0.82mm², Recommended cable model: UL2464-1*2*18AWG)

1.5.1 Synchronous signal wire install location of the container

Synchronous signal terminal on the GPC's X1 board, J40 is signal input terminal, J39 is signal output terminal, the synchronous signal terminal location as follow:

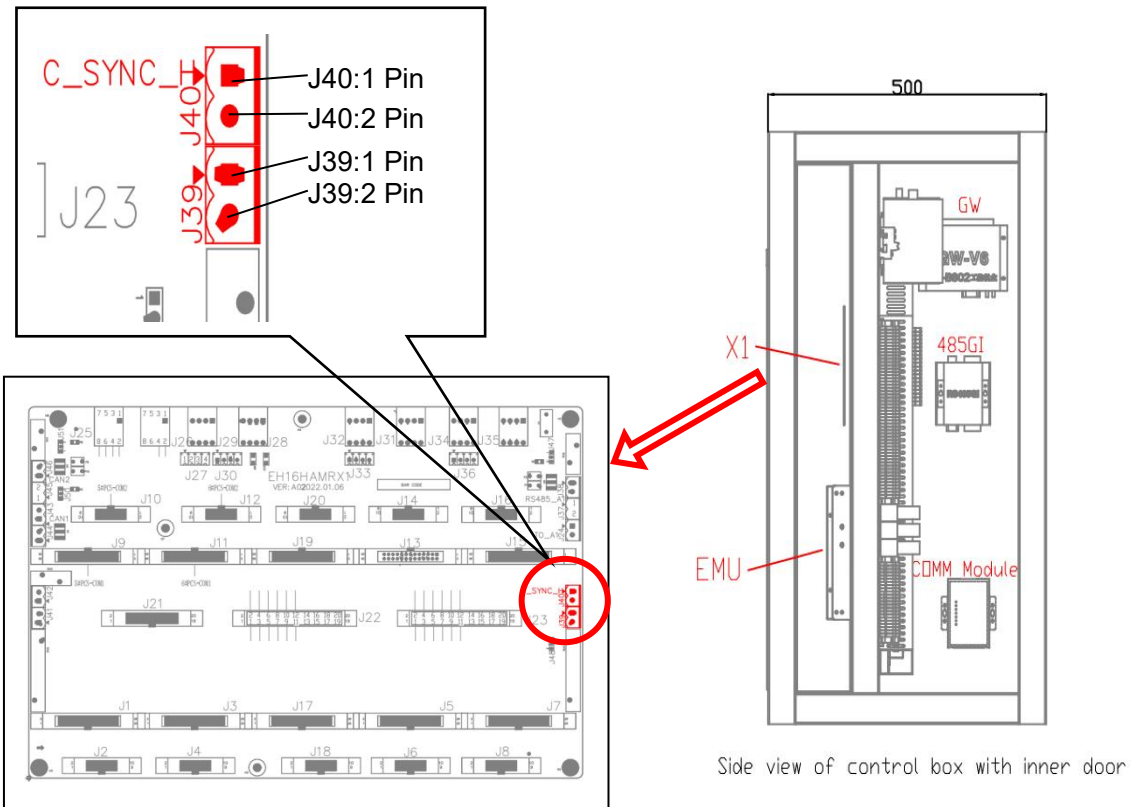

1.5.2 Connection method of synchronous signal wire

Here are some connection cases:

Case1

When 2 set 20C2H1000KLS containers connect to the same transformer cooper bar

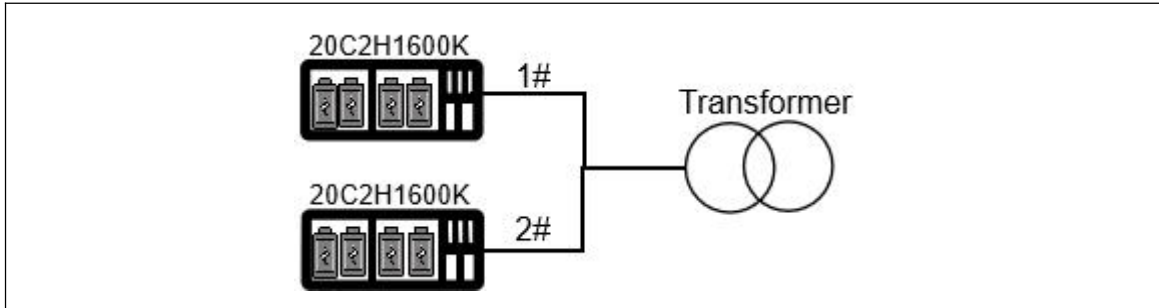

1#container



2#container

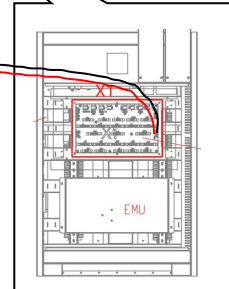
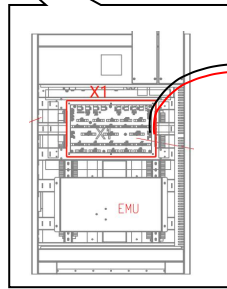

Case1: When 2 set 20C2H1000KLS containers connect to the same transformer cooper bar			Remark
Start terminal	Connect cable	End terminal	Cable color is only used to differentiate between locations.
1# container-J39:1	Red wire	2# container-J40:1	
1# container-J39:2	Black wire	2# container-J40:2	
Note: The wire length between containers can't longer than 10m.			

Case2
When 3 set 20C2H1000KLS containers connect to the same transformer cooper bar

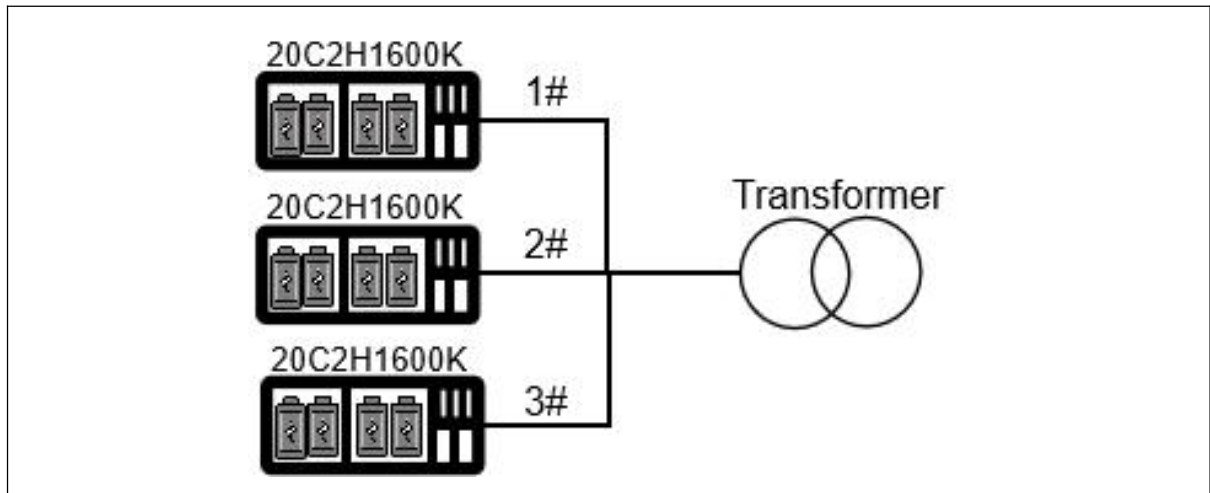

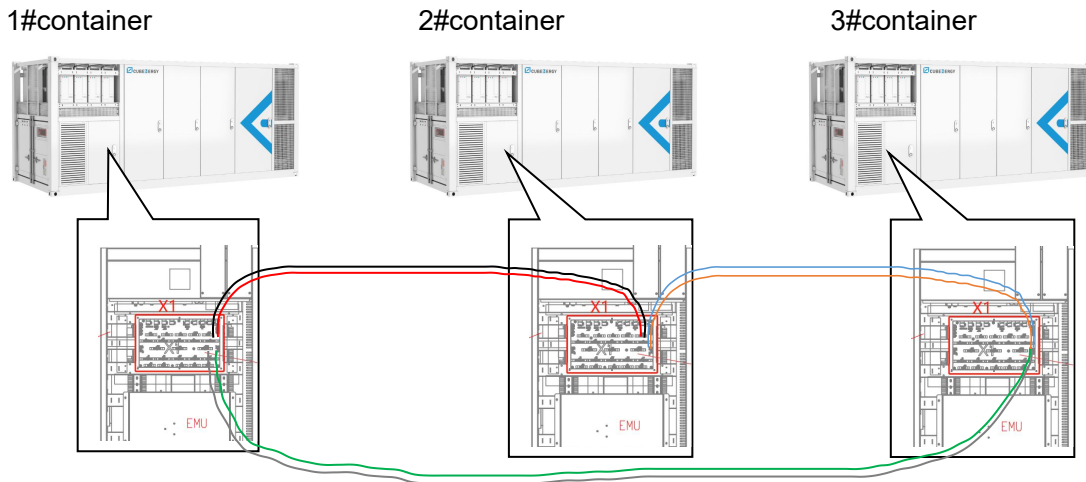

Case2: When 3 set 20C2H1000KLS containers connect same transformer cooper bar

Start terminal	Connect cable	End terminal	Remark
1# container-J39:1	Red wire	2# container-J40:1	Cable color is only used to differentiate between locations
1# container-J39:2	Black wire	2# container-J40:2	
2# container-J39:1	Blue wire	3# container-J40:1	
2# container-J39:2	Orange wire	3# container-J40:2	
3# container-J39:1	Green wire	1# container-J40:1	
3# container-J39:2	Grey wire	1# container-J40:2	

Note: The wire length between containers can't longer than 10m.

1.6 Work after connection

Step 1: Cut the bottom inlet hole baffle

Cut the inlet hole baffle according to the inlet cable.

Tool name	picture
-----------	---------

Cutting machine



Step 2: Install the inlet hole baffle

Install and fix the cut inlet hole baffle

Tool name	picture
-----------	---------

Electric hand drill



Double head cross head



Step 3: Use flexible flame retardant materials to seal the gaps

Use flexible flame-retardant materials to plug the gaps between cables

Step 4: Iron plate mounting

Tool name

picture

Electric hand drill



Double head cross head

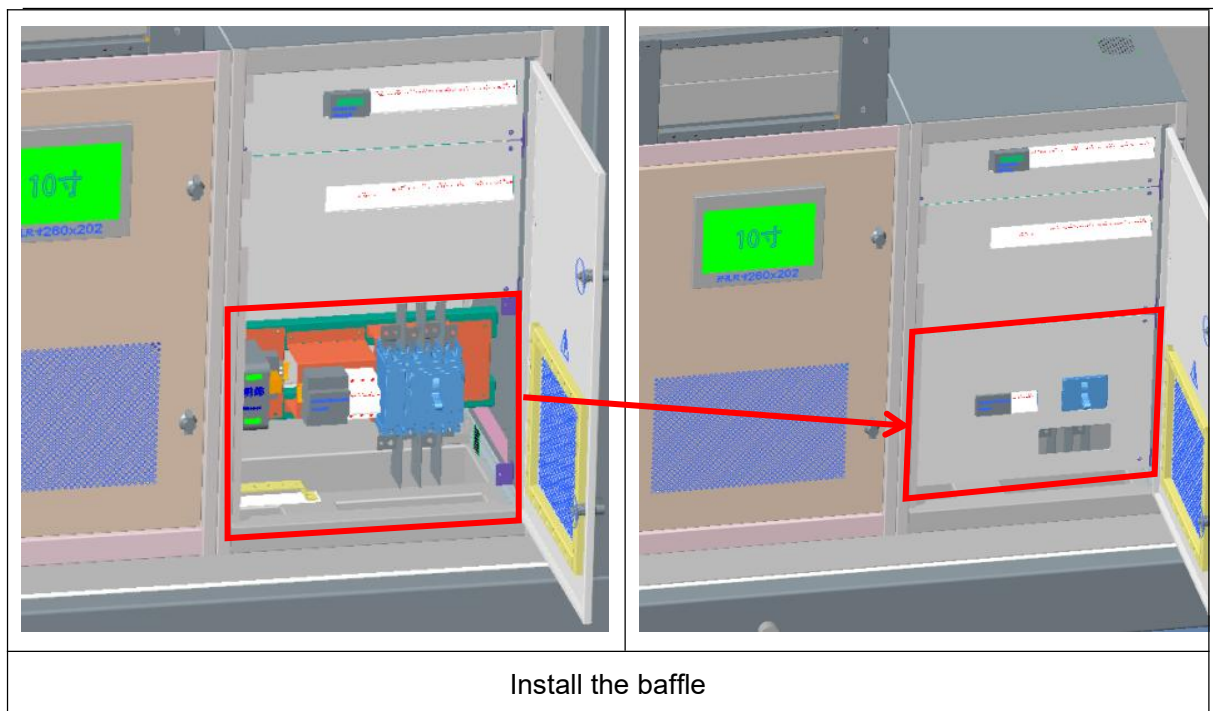

Figure 6-23 Install the baffle,close the door of distribution box(DB),