

Datasheet



GREEN LINE

KT-LFP12200-GL

Green Line LiFePO₄ Battery

Lithium-iron-phosphate

Equipped with heating pads and wireless communication

12,8V | 200Ah

TECHNICAL SPECIFICATION

PARAMETERS

Rated voltage	13.2V±0.1V (C/20)
Nominal voltage	12.8V
Nominal capacity	200Ah
Nominal energy	2560Wh
Cycle life 100% DoD	2500 cycles
Cycle life 80% DoD	3500 cycles
Capacity decrease	30% after 2500 cycles @100% DoD
Predictable chemical durability	minimum 12 years
Efficiency	97%

CHARGING / DISCHARGING

Recommended charging voltage	14.6±0.2V
Maximum charging current	200A
Recommended charging current	40A
BMS charging cutoff voltage	15V (3,75V per cell)
Balancing voltage	14,4V (3,6V per cell)
Charging method	CC/CV
Charging time	10A – 20h / 20A – 10h
Maximum continuous discharge current	200A
Maximum peak discharge current	220A (5s)
Low voltage cutoff	10V
BMS minimum cutoff voltage	10V
Reconnect voltage	11V

OPERATING CONDITIONS

Heating pads	Yes
Operating temperature	-20°C to 60°C
Charging temperature	-20°C to 45°C
Storage temperature (3 months)	-20°C to 45°C
BMS temperature cutoff	65°C (charging) 75°C (discharging)

OTHER

Weight	21 kg
Dimensions (without terminals)	493 × 173 × 245mm
Terminal height	~25mm
Terminal type	M8
Terminal torque	8-10 Nm

COMMUNICATION

Wireless communication	Yes
------------------------	-----

COMPLIANCE

Certificates	CE, UN38.3
--------------	------------

Battery has a internal Battery Management System BMS.

PROTECTION TYPE

Overcharge, overdischarge, short circuit, high temperatures, passive cell balance.

DIMENSIONS

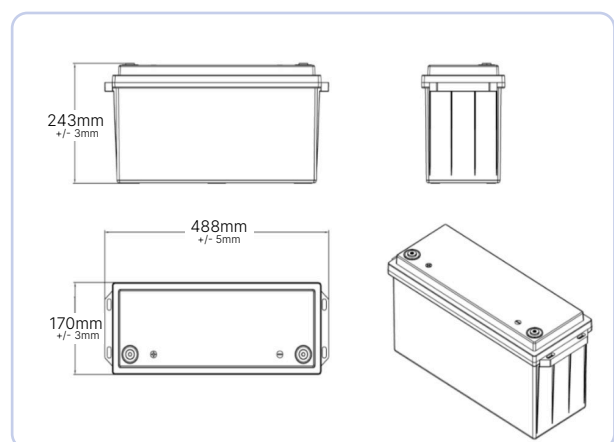

MAIN PRECAUTIONS

- Do not expose the battery to UV radiation.
- Do not immerse the battery in water.
- Do not place the battery near heat sources.
- Charge the battery only under supervision
- Do not short circuit + and - terminals with any conducting elements.
- Do not connect the battery directly to electrical socket.
- Do not throw the battery into fire.
- Do not transport the battery together with metal objects
- Do not hit, throw or step on the battery
- Do not puncture the battery with any objects
- Do not dismantle or open the battery
- Do not store unused battery for a long time
- Do not leave the battery in high temperature conditions
- Do not use the battery near high electrostatic or magnetic field.
- Read the charger manual carefully.
- Store the battery with secured terminals.
- Keep the battery away from children and animals.
- Do not wear metal objects during operating with the battery
- Charging time should be no longer than given in charger manual
- Do not solder anything to the battery.
- Do not expose the battery for microwaves or high pressure
- Do not apply any form of pressure to the battery.
- If the battery emits a strange smell, is noticeably hot, changes colour, deform or deviates from the norm in any other way during operating, immediately disconnect it from the load and take it in safe place, next contact with supplier
- If the battery terminals are contaminated, They should be cleaned by a dry cloth. In other case the battery connection may be faulty

STORAGE AND LIFETIME

The batteries should be stored under following conditions

- In ventilated places avoiding direct UV radiation
- In case of long term storage it should be performed in low humidity places and the temperature range of -10°C to +45°C.
- Store the battery at full State of Charge.
- If the battery is going to be stored 6 months or LONGER, at least one full cycle, charging and discharging, is required to prevent damage of the cells through self-discharge process.

Number of cycles after which the battery retains its 80% of nominal capacity depends on depth of discharge.

Cycle number is no less than 2,500 while discharging 100% DoD. After exceeding 2,500 cycles the battery is still efficient, its capacity is no less than 80% of nominal capacity and it starts to decrease along the time and/or further operating.

The shallower the discharge cycles, the longer the lifetime. Accordingly, for 80% DoD cycles (discharge to 20% of nominal capacity, lifetime is 3,500 cycles.

The estimated lifetime of the battery electrolyte is taken as 12 years of use.

WARNING

Due to the non-linear nature of LiFePO₄ battery discharge its voltage ranges are almost constant, In a wide range of its capacity (Fig. 1).

Nominal voltage of 12.8V (for our batteries) may indicate either a charged battery at 90% of SoC OR ALSO discharged battery near 0% of SoC.

As can be seen from the characteristics, a battery with 12.8V resting voltage (open circuit, no load) can be practically fully discharged. Therefore, in case of LiFePO₄ batteries, their voltage may not be used to estimate their actual state of charge.

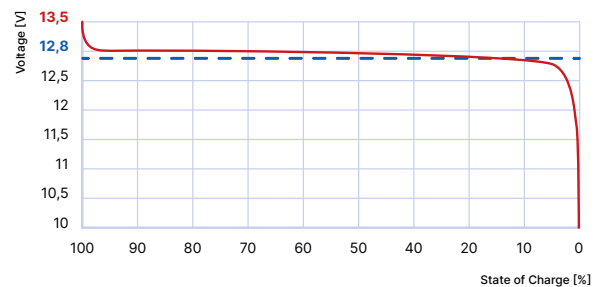
Fig.1 LiFePO₄ battery voltage drop, 1C discharge

It should be never allowed a situation in which the resting voltage of the LiFePO₄ battery terminals is less than 12.8V.

WARRANTY TERMS

For the above product, which is a LiFePO₄ battery, the customer is provided with a warranty that the product will be free from material and manufacturing defects for a period of 2 years from the date of purchase in Poland.

If, during the warranty period, the customer experiences symptoms that may indicate a product defect, please contact the technical support department, which will advise on further actions. Under this warranty, the defective product will be restored to operating order or replaced, if the defect makes it impossible to repair.

The warranty will be considered within no longer than 30 working days from the date of reported complaint. The replacement of the device includes the delivery of a new, defect-free product, the same or, if it is withdrawn from production, with similar parameters, excluding dimensions that may change. Traces from service activities may remain on the outer case of the battery.

The warranty does not apply:

- in case of improper connection, operating, charging or discharging the battery,
- in case of product modification, dismantle, change or damage as a result of improper operation,
- in case of non-compliance to device operating manual,
- in case of selling a product at a public auction,

- in the event of destruction of the device during an accident or natural disaster,
- in case of damage to battery terminals
- in case of destruction of the device by fire, freezing or high temperature,
- in case of flooding/crushing due to pressure of the device,
- in case of user interference with the device,
- in case of damage to the device case.



Kon-TEC Sp. z o.o.



ul. Boya-Żeleńskiego 12 /B
35-105 Rzeszów, Poland



+48 572 001 150
info@kon-tec.eu
www.kon-tec.eu